



ALBUQUERQUE PUBLIC SCHOOLS

Department of Facility Design & Construction
Department of Maintenance & Operations

ELECTRICAL SYSTEMS DESIGN STANDARDS

FINAL Ver.3.1

January 2018
Michael McMurphy

Introduction

It is the intent of these APS Electrical Systems Design Standards to insure quality and consistent electrical/special systems installations throughout the Albuquerque Public School District. These standards are not intended to replace or supersede applicable local, state or national electrical codes, rather supplement them with installations, products and practices that have been found effective for use in public school settings. If there is found to be a conflict between these standards and any current/enforced applicable electrical code, then the more stringent requirement shall be used.

Specifications shall follow the Construction Specifications Institute (CSI) Masterformat Numbering System

APS ELECTRICAL STANDARDS

ISSUE DATE: January 2018

PREVIOUS ISSUE: September 2016

(Please check APS Website to verify latest edition)

<http://www.aps.edu/facilities-design-and-construction/design-standards-and-guidelines>

Click on Page #

<u>SECTION</u>	<u>TITLE</u>	PAGE
A	SITE ELECTRICAL	4
B	INTERIOR LIGHTING	7
C	RECEPTACLES & POWER	10
D	HVAC POWER & CONTROL	12
E	POWER DISTRIBUTION	13
F	STANDARDS FOR INTERCOM, FIRE AND SECURITY	15
G	TELE & DATA COMMUNICATIONS	27
H	ENERGY CONSERVATION	34
I	STANDBY ENGINE GENERATORS	35
J	RENOVATION & RE-ROOFING	36
K	INFRASTRUCTURE FOR PORTABLES	39
L	MISCELLANEOUS	42
	APPENDIX "A" – ELECTRICAL IDENTIFICATION	44
	APPENDIX "B" – STANDARD DRAWING	45

A. SITE ELECTRICAL

1. Coordinate scale of site plan and north arrow orientation with Architectural Plans
2. Coordinate with local utility companies (power, telephone and cable TV). Send plans to respective utility company and follow up with letter to the file and architect.
3. Power – Verify location of pad mount transformer with architect
4. Telephone – Extend telephone conduit (minimum 2-4" C) with marking mule tape to the corner of the property line. Telephone conduit shall be noted to have long sweep elbows and bends and to be installed minimum 36" below grade. Specify spare conduit. Conduit elbows to be wrapped Rigid or IMC.
5. Cable TV – Empty 2" C in same trench as telephone
6. Coordinate with Landscape Architect for power to the irrigation controller (wp receptacle where located outdoors). Coordinate with Civil Engineer for location of "hot box" and backflow preventer (irrigation and/or domestic water). Weatherproof j-box and #10 branch circuits.
7. Coordinate with Civil Engineer for fire sprinkler PIV (Post Indicator Valve). Weatherproof j-box and 1" C with 4#10 in ¾" C to the fire alarm control panel.

a. Site Lighting

8. Coordinate with Architect and APS for site lighting. Specify details for site lighting concrete base foundations. Submit calculations for voltage drop on branch circuits and design for minimum #8 conductors and 1.5" C for all exterior pole lighting. Lighting poles shall be aluminum or steel, no fiberglass or wood. See pole base detail in this section.
9. In parking lots and drives, design for an average maintained level of 1 footcandle (FC) with a minimum of 0.2FC and maximum to minimum uniformity ratio of 20:1. For building mounted lighting, courtyard or patio lighting, and other exterior lighting, use full-cutoff fixtures. Design exterior lighting with at least two circuits, one for security (dusk-to-dawn) and one for convenience (dusk or timed on, timed off). Control through time clock, discuss with APS for regards to lighting schedule.
10. Submit "exterior lighting control diagram" and design parking lot and marquee type lighting in individual zones (do not put building and parking on the same circuit). Coordinate with APS for operation and control of exterior lighting. Specify a Time clock with "astronomical features" for control of exterior lighting, Consult with APS for specific time setting requirements. (See Section H #9 Energy Conservations and #26 this section).
11. All roadway lighting will be programmed to start a ½ hour before dusk and off a ½ hour after dawn.
12. Parking lot area lighting will be programmed to start a ½ hour before dusk and off at 11 pm; on at 5 AM, off at sunrise.
13. Walkway lighting will come on a ½ hour before dusk and off at 11 pm; on at 5 AM, off at sunrise.
14. Designated walkway lighting will be on a ½ hour before dusk and off a ½ hour before dawn. Consult APS if needed.
15. Building-mounted lighting will come on ½ hour before dusk and off a ½ hour after dawn
16. Specify data outlet in ALL electrical rooms
17. Specify vandal resistant lenses for ALL exterior lighting and on all exterior pole lights and house side shields in residential areas.
18. Lighting shall be designed to comply with the New Mexico Night Sky Protection Act, the "City of Albuquerque Lighting Ordinances" and all other ordinances and covenants related to exterior lighting, including where projects are located in the "Coors Corridor Plan".

19. Specify lamp color, type, and wattage for all lamps utilized on the project. Use a minimum number of different lamps to simplify maintenance.
20. Submit computer point-by-point calculations for parking lot lighting. Check with APS for approval.
21. Do Not use bollard type exterior lighting fixtures
22. Do Not use any type of flush-in-grade light fixtures
23. Do Not use ground mount fixtures or exterior fixtures that are within easy reach from grade level
24. All exterior lighting shall be LED type fixtures, **NO EXCEPTIONS**
25. Exterior Fixtures shall be located to be maintenance friendly, “wireless control of pole lighting can be discussed with APS at plan review as an option”
26. All exterior lighting shall be controlled by Intermatic time clocks Model ET90215 CE for 1-2 Circuits; Model ET904 15CR for four circuits, (more than 4 circuits requires an ET9250 Relay) zoned at time of design / provide data drop at time clock location
27. No PV on parking lot poles – **NO EXCEPTIONS**
28. Neatly tack weld mounting bolts on all pole lights to help prevent copper theft
29. Pole light hand holes shall have vandal resistant covers
30. Provide 3-Phase total system monitoring that reports to security system (consult with APS M & O Electric Department) intent to notify APS Police (505-243-7712) and APS M & O Electric Department (505-765-5950 ext. 67532) of phase or power loss. See Power Distribution #26.

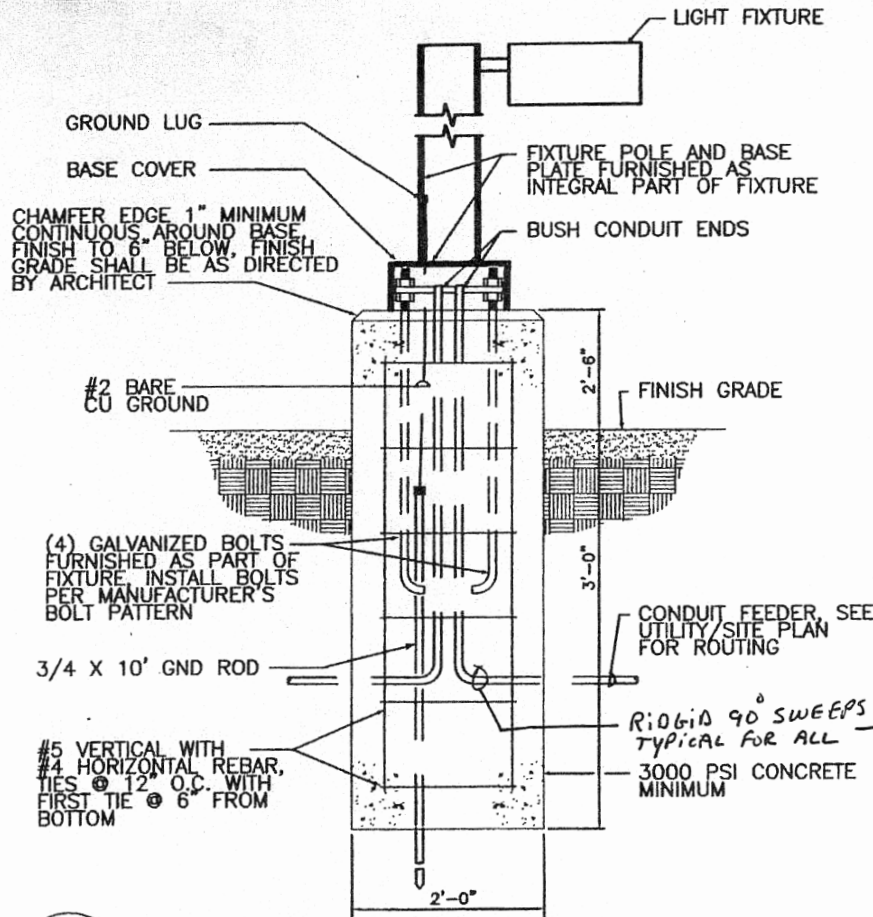

POLE BASE DETAIL -

SCALE: NONE

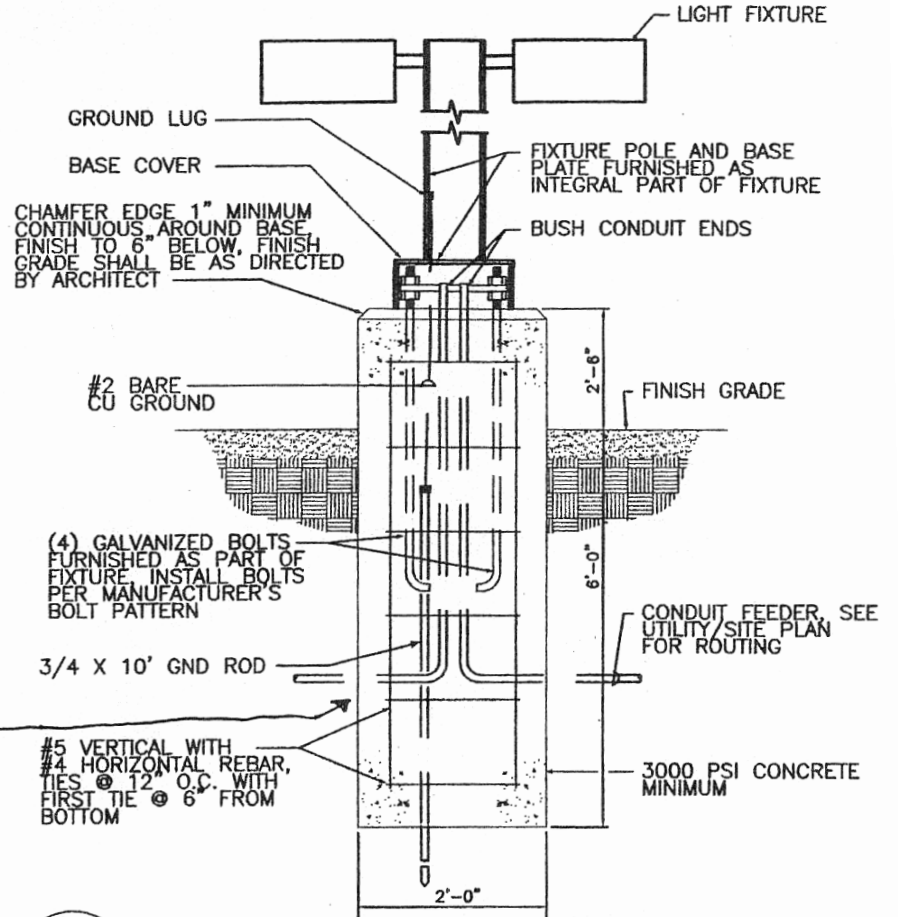

POLE BASE DETAIL -

SCALE: NONE

B. INTERIOR LIGHTING

Follow current IESNA recommendations for lighting design. Comply with the latest edition of the International Energy Conservation Code (IECC) for lighting power density and controls. Discuss the choice of time scheduling versus occupancy sensing with APS before making a selection for interior lighting control. Comply with NFPA Standards for emergency and exit lighting.

1. Coordinate with architectural reflected ceiling plans for correct ceiling type and verify compatibility of fixture type with ceiling construction.
2. #12 AWG light fixture whips
3. Coordinate with mechanical engineer for light fixture and duct layout and verify height of location of ductwork above ceiling to avoid conflicts with depth of light fixtures.
4. Submit illuminance calculations (point-by-point) in typical areas including offices, classrooms, hallways, and unique areas such as gym, library and cafeteria.
5. Design all rooms and spaces to be adequately illuminated. Do not leave any areas under-illuminated or without any illumination. Design light levels to comply with current IESNA recommendations.
6. Show mounting details for all suspended linear fluorescent fixtures. Show mounting details for High-Bay fixtures.
7. Emergency light fixtures shall be located within 10'-0" of all exterior doors, and minimum 50'-0" on centers in corridors. Emergency light fixtures shall be mounted maximum 10'-0" AFF.
8. Emergency Light and exits to be individual battery pack / No centralized battery/inverter systems.
9. Specify exit lights at all exterior doors, intersection of corridors, and minimum 100'-0" on centers in corridors.
10. **Designed keyed switches on line side of all motion/vacancy sensor switches; to be used as a service disconnect for maintenance.** This allows for required lockout/tagout NFPA 70e of local circuit without shutting down entire circuit at panel in order to minimize lighting outages.
11. Lights fixtures in stairwells shall be on keyed switch.
12. All Single Pole keyed switches shall be Leviton 1221-2iL; all 3-way keyed switches shall be Leviton 1223-2iL (No substitutions)
13. Design for dimming of LED lamps in fixtures in classrooms and office (where applicable for energy conservation).
14. Design high-bay LED fixtures in high bay areas. Gymnasium as an example, gyms and mini-Gyms – utilize LED fixtures with polycarbonate lenses and wire guards.
15. Specify LED type exit lights with maintenance free batteries.
16. Specify **ALL** emergency lighting to be wall mounted with dual heads and maintenance free batteries.
17. Specify keyed switches to be 1223-2iL (3-way), and 1224-2iL (4-way)
18. Design 4' utility strip fixtures with high abuse lenses in utility pipe chases (between toilet rooms).
19. Specify high abuse (.187" thick poly carbonate) lens in storage, custodial closet, equipment rooms, and gyms.
20. Teachers' lounge shall be vacancy type sensor. Specify occupancy sensors in toilets, storage rooms. Specify "off-auto" keyed switch for occupancy sensors in toilets. The engineer shall review occupancy sensor and switch locations and types with APS during the 50% review meeting. Use ceiling mount sensors in student accessible areas.

21. Specify clear polycarbonate cover for all emergency battery operated light fixtures in gymnasiums with hole drilled in bottom for access to “Test” pushbutton.
22. Design emergency egress lighting to be located immediately adjacent to exterior egress doors. (As per IBC).
23. Lumen levels shall conform to current IES recommendations (www.iesna.org) and shall not exceed recommended levels by more than 10%. Must meet state standards:

*NMAC Statewide Adequacy Standards:
6.27.30.12 ACADEMIC CLASSROOM SPACE*

C. Classroom lighting

(1) Each general and specialty classroom shall have a light system capable of maintaining at least 50 foot-candles of well-distributed light. Provide appropriate task lighting in specialty classrooms where enhanced visibility is required.

(2) The light level shall be measured at a work surface located in the approximate center of the classroom, between clean light fixtures.

- A. SKYLIGHTS: Do not install any light fixtures in skylight wells, unless otherwise approved by APS. Lighting around the perimeter or within 8' of skylight shall be controlled from an independent keyed switch separate from the Corridor or Hallway lighting, located adjacent to the skylight. No “up lighting” on windows.
- B. CLASSROOMS: Vacancy Sensors – Ceiling mounted dual technology vacancy sensors will be the master off control of room luminaires. When motion/sound is not detected lighting will shut off. When motion/sound is detected lighting will not automatically return to previous switch condition unless vacancy sensor switch is switched on to allow the control circuit to continue. A single 3-way single pole double throw (SPDT) switch will be used to control a three lamp luminaire in the following fashion; either two outbound lamps on or single inboard lamp on, but neither will be on at the same time.
- C. RESTROOMS, LARGE AND SMALL:
 - a. Large Restrooms and Locker Rooms: Dual technology (Ultrasonic/infrared) occupancy sensor will be wired after switches to control for entire room. Keyed switches will be used as a service disconnect. Use ceiling mount sensor in student accessible areas. Consider time out @ 15 minutes.
 - b. Small Restrooms: The wall-mounted occupancy sensor will control the luminaries and in some cases, the exhaust fan
- D. UTILITY ROOMS (Storage, janitor and the like): Wall-mounted occupancy sensor will control the luminaire(s) in the room.
- E. OFFICES: Wall-mounted occupancy sensor will control the luminaire(s) in the room; another sensor type could be a ceiling mounted sensor for large offices.
- F. CORRIDORS AND STAIRWELLS: Primary control will be via a time clock. Program set times will be on at 6 am and off at 11 pm, or as designated by APS requirements. Between 6 am and 11 pm local control of luminaires will be via a keyed switch; between 11 pm and 6 am control of luminaires will be via a keyed override switch located near entrance. Used in a security situation.
- G. GYMNASIUM LIGHTING:
 - a. Occupancy sensor will be the master control of room. When motion/sound is not detected lighting in room will shut off. When motion/sound is detected lighting will return to previous switch condition.
 - b. Dual toggle switches will be secondary control of luminaries in rooms. After occupancy sensor detects persons in room the dual switching will provide occupant control of the room luminaries.
- H. GYMS/MINI-GYMS: Utilize HO LED fixtures with polycarbonate lenses and wire

guards.

- I. COMPUTER LABS: Use indirect or indirect/direct fixtures with dimmers. Design for maximum 50FC to allow use of room for normal teaching.
 - J. MULTI-PURPOSE ROOMS: Fixture design and placement shall be concentrated at the task. Provide dual level switching.
 - K. RESTROOMS WITH STALLS: A flush ceiling motion/sonic occupancy sensor.
 - L. LARGE STORAGE AREAS: All light fixtures shall be specified with high abuse lenses. Utilize LED fixtures. Lighting shall be controlled by ceiling-mounted occupancy motion/sonic sensor(s).
 - M. KITCHENS: Utilize LED fixtures with dimming feature 2x4 flush or surface mount, vandal-resistant, with inverted acrylic prism lens.
 - N. Avoid use of pendant fixtures in cafeteria
- 23. Lighting design and fixture locations shall take precedence over ceiling tile layouts. Provide attachments detailing lighting fixture installations, controls, and foot-candle calculation levels.
 - 24. Design stair well lighting to be accessible from landings.
 - 25. Use LED for general lighting. Use 3500K, 82 CRI minimum.
 - 26. Minimize the number of different lamps on a project to simplify maintenance.
 - 27. **Do Not** use incandescent lamps.
 - 28. **LED lighting shall be used for ALL interior applications.**
 - 29. Specify 2 adjacent corners of all 2x4 lay-in fixtures are secured to structure.
 - 30. Specify 2x4 lay-in light fixture whips to be fed from ceiling mount J-Boxes – Fixtures shall not be wired fixture to fixture.
 - 31. LED lighting shall be used for ALL recessed can applications, interior or exterior.
 - 32. Interior Fixtures shall be located to be maintenance friendly.
 - 33. Design LED type lamps and compatible dimmers when track lighting is used.
 - 34. Specify all switches to be provided with permanent circuit labeling indicating panel fed from and branch circuit.
 - 35. Control illumination of video wall independently from other classroom fixtures.
 - 36. Avoid placement of restroom light fixtures above toilets.
 - 37. Specify device plates to be brushed stainless steel type for indoor locations.
 - 38. Decora style switches and receptacles not allowed

C. RECEPTACLES AND POWER

1. Safety tamper resistant receptacles in all elementary and middle school applications; this also applies to high school day care areas, gym lobbies, waiting spaces, etc. (2017 NEC 406.12).
2. Design duplex outlets in all rooms, spaced correctly and according to function of the space. Design fourplex outlets in offices adjacent to desks.
3. Specify and locate special purpose outlets with NEMA configuration and mounting heights. Coordinate with architectural and mechanical plans, as required, for correct voltage, phase, and number of wires.
4. Specify all outlets to be mounted in conformance with ADA rules and regulations.
5. Coordinate outlet heights and location with architectural interior elevations (casework, sinks, lavatories, etc.) specifically in vocational shops, kitchens, computer labs, science labs, etc.)
6. Specify outlets to be mounted up +48" AFF in vocational labs, wood working shops and similar spaces.
7. Specify duplex outlets with 20A GFI protection within 6' of all janitor closets, restrooms, and sinks, exterior of buildings, and elsewhere as dictated by the NEC.
8. Specify all outlets and switches to be provided with permanent labeling identifying panel and branch circuit connected to.
9. Specify all 120V circuits over 100' (single wire length) to be minimum ¾"C with minimum #10 AWG branch circuits. Design all circuits for maximum 5% voltage drop from utility transformer.
10. Design a 120V branch circuit to all exterior door locations for ADA opener and electronic hardware card reader, electric strike.
11. Specify wiremold #5400 series surfaces mounted raceway system in computer classrooms. Discuss appropriateness of power pole design in Computer Rooms with APS.
12. Specify weatherproof 20A GFI unswitched duplex outlets with metal in use covers/unswitched on the roof at NEC required intervals (25ft). Coordinate with requirements listed under "HVAC Power and Controls".
13. Review specific Computer power requirements with APS during the design phase.
 - a. Design dedicated circuits for Computer Labs (Refer to "Power Distribution")
 - b. Specify TVSS type receptacles for telephone equipment, MDF and IDF equipment
14. All exterior duplex receptacles shall have metal in use covers.
15. Design wp GFCI Duplex for all sewer cleanout locations for rooter equipment.
16. Provide 120V dedicated circuit, for all exterior backflow prevention "Hot Boxes". – 1 duplex GFCI, 1 simplex outlet for heat tape & cable.
17. Design dedicated circuit outlets for copier machine locations.
18. Control wall oven units in kindergarten classrooms (if appliance installed) thru 50 AMP contractor mounted above ceiling. Control circuit shall be a lighted toggle switch located next to wall oven unit. Label switch plate –"Safety Shut for Oven Unit"
19. Avoid use of floor outlets (data/power) **unless absolutely necessary, or in meeting rooms greater than 1000 sq. ft. (2017 – 210.7 1(B) NEC)**. If floor box is needed, use a raised tombstone style box and trim, example, conference room. Floor boxes are more durable when installed on carpeted floors rather than smooth floor surfaces.
20. Provide double duplex with dedicated circuit in all electrical panel rooms.
21. Decora style switches and receptacles not allowed.
22. Specifically prohibit by blueprint keyed note, use of stranded conductors to terminate

receptacles and switches.

23. Design all office and computer classrooms to comply with ASHRAE 90.1, 2010, which requires 50% of convenience receptacles in offices and computer labs be switched with automatic control. Controlled outlets to be identified as per 2017 N.E.C. ART 406.3(E)
24. All classroom walls shall have a minimum of 2 duplex outlets per wall.
25. Design plug and cord reels with appropriate style and function in all specialized classrooms, culinary arts, computer labs, science labs, etc. Locate reels strategically for greatest flexibility of use.

D. HVAC POWER AND CONTROL

1. Coordinate with mechanical engineer for proper voltage, phase, minimum circuit amps, etc. for all HVAC equipment. The electrical engineer shall review the mechanical submittals to ensure electrical design parameters match electrical characteristics of mechanical equipment being supplied on the job.
2. Specify all HVAC equipment to be provided with fused protection anything over $\frac{3}{4}$ HP (or HACR breaker if allowed by the manufacturer). Provide an external disconnecting means at all HVAC equipment. Evaporative coolers with internal receptacles for motor and pump connection shall also be equipped with a disconnect switch external to the unit. Size breakers and fuses in accordance with the NEC and manufacturer's recommendations.
3. Specify WP GFI duplex receptacles installed with 25' of each HVAC unit on the roof, or as dictated by the NEC.
4. Specify permanent Micarta labels to be provided on all starters and disconnect switches indicating panel fed from and circuit connected to.
5. Specify pilot light switches for control of all exhaust fans, unless otherwise controlled by time clock or from building automation system.
6. Coordinate with mechanical engineer for location and wiring requirements of combination fire/smoke dampers. Design for 120V control power, systems duct smoke detector (located in duct and within 3' of fire smoke damper) and fire alarm connections.
7. Coordinate HVAC systems control with mechanical engineer. Coordinate location of t-stats and associated wiring. Provide control diagrams for all HVAC equipment as required by the mechanical engineer.
8. Specify starters for pumps and fans over 1HP. Specify NEMA Size, NEMA enclosure type, mounting, and control features. All motors 1HP and less shall be designed for 120V. All motors larger than 1HP shall be designed for three phase power if available on-site.
9. Specify stranded conductors in flexible conduit for all mechanical equipment, from the unit to the nearest termination point that is vibration free.
10. Specify systems duct smoke detectors for all HVAC units (2000 CFM and greater return and/or supply air – verify with the mechanical engineer). The duct smoke detectors shall be connected and powered from the building fire alarm system and shall be furnished by owner and installed by an APS special systems contractor.
11. Evaporative coolers up to and including 1HP shall be specified for 120V power, two speeds.
12. Specify non-fusible disconnect switches for all 120V evaporative coolers (where pump and fans are provided with inherent motor overload protection).
13. Require all HVAC DDC systems conductors to be in a complete conduit system
14. Specify labeled red mushroom head kill switch for emergency disconnect of boiler system
15. For building automation systems, specify three (3) data drops in the location of the main DDC control panel (one for the controller itself, one for interconnection between the equipment/controller, and one for laptop internet connection). Also, provide a 110V power outlet near the control device. For multi-building or multi-story applications using sub-controllers, provide one data drop at the location of each sub-controller.
16. **For large 3-Phase motors, specify line voltage phase protection monitors.**

E. POWER DISTRIBUTION

1. Coordinate with Public Service Company of New Mexico (PNM) and comply with their rules and regulations. Use PNM's "Power Planning guide" and specify drawing numbers. Send plans to PNM and follow up in writing to verify items discussed regarding equipment locations, service entrance requirements and metering. Specify all primary feeders to be concrete encased. Refer to "Medium Voltage Distribution". (#24 power distribution).
2. Include Grounding details.
3. Specify "Main Building" disconnect switch (located on the exterior of the building or otherwise per NEC). No more than 6 handles, if a single main is not provided.
4. Perform Load Calculations and Short Circuit Calculations and include in the electrical drawings.
5. Specify a main over current protective device for panels installed on the secondary side of dry type transformers. Provide panels with main circuit breaker or design main device within 25' of the transformer.
6. Specify minimum clearances in front of panels, and double working clearance in front of switchboards over 1200 amperes. (See N.E.C. ART. 110.26). All electrical room doors shall have panic push bars and swing outward from room.
7. Specify panels to be located in rooms solely dedicated to electrical equipment. Scale all gear to ensure there are no space conflicts. Locate all main distribution switchboards and panel boards in an interior room (Do not locate on the exterior of the building).
8. Show routing of all major feeders and panel board feeders in plan view. **Compact aluminum feeder conductors**, 250 MCM and over will be considered as a cost savings measure, consult with APS.
9. Specify conduit stubs and permanent marker for future building construction (from main distribution equipment or sub-panels). Specify pull strings in all empty conduits and provide a tracer, solid bare copper conductor.
10. Specify minimum five (5) $\frac{3}{4}$ " C from panels (recessed flush in wall) and stubbed to above accessible ceiling areas.
11. Power Quality for Non-Linear Loads and Harmonics:
 - a. Specify 120/208 volt panels with 100% rated neutrals.
 - b. Specify K-rated dry type transformers (K-rating as required by load).
 - c. Specify 120V branch circuits with 100% rated neutral.
 - d. Specify harmonic filters where applicable. Discuss with APS on a case-by-case basis.
 - e. Specify TVSS devices on panels (main and sub-panel protection).
 - f. Specify TVSS type receptacles for sensitive electronic equipment (telephone switch, MDF's, IDF's).
12. Specify branch circuit panels with door-in-door fronts and copper bus.
13. Provide General Notes on the electrical drawings to have the contractor meggar and torque all panel feeders and to measure resistance to ground at the service ground, and to provide documentation. Owner shall witness all tests.
14. Main distribution gear (switchboards and panel boards) shall have circuit breaker type over current protective devices (fuse and switch devices will not be allowed).
15. Review electrical distribution system design concept and/or service upgrades all projects with APS personnel during the design development stage of design.
16. On all electrical renovation projects, as-built and trace all branch circuits affected by removal of walls and/or ceilings.

17. Add general note to the electrical plans to have the Contactor install typewritten panel schedules and panel labels on all panels prior to the final observation of the project.
18. Add general note to the electrical plans to have the Contractor trace all branch circuits in existing panels, on renovation projects, and to identify loads in the panel typewritten directory, in a descriptive manner (i.e.–Receptacles – West Wall Room A013”).
19. Specify that all branch and feeder circuit wiring to be color coded throughout the entire electrical distribution system as follows:
 - 120/208V Electrical Distribution: Phase A – Black, Phase B – red, Phase C – Blue, Neutral – White, Equipment Ground – Green
 - 277/480V Electrical Distribution: Phase A – Brown, Phase B – Orange, Phase C – Yellow, Neutral- Off/White or Gray, Equipment Ground – Green
20. Specify all panel feeder conductors to be properly colored insulation for entire length of run.
21. Design 20% spare ampacity into all service panels, breaker space and feeder conductors.
22. If solar system used, design isolation switching, and include M&O training.
23. Programmable circuit breaker panels are NOT to be used.
24. Medium voltage distribution (over 600V):

NOTE – do not consider design of a medium voltage distribution system without prior discussion with APS

- a. Specify duct banks to be concrete encased and installed minimum 42” below grade to top of conduit with warning tape 12” above concrete.
 - b. Specify all medium voltage cable and terminations to be “hi-pot” tested with documentation.
 - c. Specify vaults and pull boxes to be pre-cast concrete, minimum 8’x8’x8’.
 - d. Design to be a “looped’ primary distribution with S&C PMH-9 15kV switchgear, with two (2) switches and two (2) fuse bays.
 - e. Design shall be coordinated with APS Maintenance & Operations.
 - f. Specify spare fuses in the 15kV pad mounted gear to be installed inside the door of the gear. Specify label on the outside of the door ‘SPARE FUSE INSIDE DOOR’.
 - g. Specify a laminated “One Line Diagram” and power site plan to be provided and posted on the inside of the door of each 15kV pad mounted gear. The “One Line Diagram” shall include the complete design of the project.
25. Measurement and verification: Consult with APS concerning M&V on all projects. M&V is desirable to independently monitor electricity consumption. Provide data outlets at every electrical panel.
 26. Provide 3-Phase total system monitoring that reports to security system (consult with APS M & O Electric Department) intent to notify APS Police and M & O Electric Department of phase or power loss.
 27. Provide labeling on all electrical equipment as per NEC ART 110.10 (short Circuit Ratings); 110.16 (ARC-Flash Hazard Warnings); 110.21 (B) (Field Applied Hazard Markings).

F. STANDARDS FOR INTERCOM, FIRE AND SECURITY

1. INTERCOM: APS has standardized to the intercom manufactured by Rauland – Borg. The following are basic requirements for all schools:
 - a. All intercom conduit rough-in by general contractor electrical contractor to provide and install 18x18x6 terminal can in each MDF/DF
 - b. Speaker/clock unit and call switch in all classrooms, media centers and kitchens.
 - c. Speaker and call switch in all portables.
 - d. Speakers in gymnasiums, cafeterias, corridors and remote offices (not admin. area)
 - e. Handset locations in admin. Offices, nurses' office, counselors' office and reception areas.
 - f. Outside speakers to cover playground and portable areas.
 - g. Outside call back bells to cover playground and portable areas.
 - h. In new construction or remodels, wiring may be plenum rated where possible.
 - i. Locate exterior speaker and mechanical bell facing playgrounds at Elementary Schools for call-back feature.
 - j. Conduits for future extension shall have permanent marking on conduits installed above grade and where installed below grade (PVC conduit) shall be specified with permanent markers and 12 copper wires for ease of tracing.
 - k. Locate combination Speaker/Clocks in Cafeterias and Gyms (specify a wire guard for clocks).
 - l. In Gyms, Multi-Purpose Rooms, Cafeterias and Auditoriums, specify a conduit rough-in for microphones and speakers.
 - m. Design 120V simplex receptacle for connection to the 120V clock. Do not specify the clocks to be hardwired.
 - n. Locate combination speaker in all classrooms with call switch on the wall adjacent to the door. Design Sound/PA system call-in switches in all classrooms, nurse's office, coach's office, etc.
 - o. Locate ceiling mounted speakers in all toilets, corridors, lobbies and public spaces.
 - p. P.A. System punch blocks must be vertically mounted and accessible.
 - q. Locate head-end equipment for Sound/PA and Security in the MDF room dedicated solely for this type of equipment. Discuss location of room with APS during the design development phase of project.
 - r. Ceiling mounted speaker systems can be used in lieu of wall mount combination clock/speaker boxes. If a ceiling mount is used, design one simplex clock receptacle for wall mounted clock.
2. FIRE ALARM: APS has standardized to Notifier systems. The following are basic requirements for all schools:
 - a. All fire alarm conduit rough-in by general contractor electrical contractor to provide and install 18x18x6 terminal can in each MDF/IDF.
 - b. Fire alarm system shall be in a complete conduit system, 3/4" minimum.
 - c. Four inch square deep boxes with 4 square extension ring for all fire alarm speaker/strobe locations.
 - d. Fire Alarm Control Panel shall be in MDF if possible, with Fire Alarm Annunciator in main office lobby if possible.
 - e. Audio/Visuals in all classrooms, restrooms, conference rooms and media centers

- f. Audio/Visuals in all corridors, gymnasiums, cafeterias, kitchens, classrooms with no corridors and mechanical rooms.
 - g. Smoke or heat detectors in all electrical room, mechanical room, kitchens, kiln, lounges, corridors, workrooms, kindergarten/preschool, special needs rooms, wood, metal or auto shops, janitor closets portable buildings and storage rooms.
 - h. Pull stations at all exits.
 - i. Outside audio devices on perimeter of building located by intercom speaker and bell.
 - j. Design for system duct detectors provided by Sound & Signal at all HVAC systems for fan shutdown and fire alarm interlock wiring.
 - k. Locate duct smoke detectors within 3' of fire/smoke dampers and design for 120V interlock wiring.
 - l. Voice evacuation required in all e occupancies per Albuquerque Fire Department
 - m. Coordinate with Architect for Elevator "shunt trip" alternate, recall and fire hat provision (only if the shaft of the elevator is sprinkled). Locate heat detectors and smoke detectors in the shaft of the elevator within 2' of all sprinkler heads, in the elevator equipment room, and at the top of the shaft of the elevator.
 - n. Locate smoke detectors at all elevator lobbies on all floors for elevator recall. Designed to the latest code.
 - o. Design for connects to the Post Indicator Valve (PIV) on the site. Design conduit only to the School's Security Alarm System Panel. Coordinate location of PIV with the Civil Engineer.
 - p. Locate flow switches and tamper switches on all fire sprinkler risers; show connections to fire alarm system.
 - q. Coordinate with Architect for Smoke Doors, magnetic door hold open devices, panic hardware and doors requiring interlock wiring with the fire alarm system.
 - r. Design 120V, 20A branch circuit for the Fire Alarm Control Panel and power supplies and specify a locking type circuit breaker with a painted red handle in the branch circuit panel.
 - s. Design for audible/visual devices in all areas of the schools, including portable buildings. The audible/visual device shall have an adjustable db level for smaller spaces such as toilets, offices, classrooms, teacher's lounges, etc. Include manual pull stations in portable building.
 - t. Design for fire alarm connection at the kitchen hood fire protection system.
 - u. **Contact APS On-Call Contractor, Tom Burson, Sound & Signal (505) 884-1217 or Bryan Bundrant (505) 710-4648, to coordinate design of fire alarm systems.**
3. SECURITY: APS security has their own reporting equipment so no keypads, control panels or sirens are installed in schools. Following are the basic requirements for all schools:
- a. All security system conduit rough-in by general contractor; electrical contractor to provide & install 18x18x6 terminal can in each MDF/IDF
 - b. Security system shall be a complete conduit system 3/4" min.
 - c. INTRUSION ALARM SYSTEM SPECIFICATIONS:
 - i. The following specifications are provided to assume that all vendors contracted by Albuquerque Public Schools, install intrusion Alarm System and/or equipment and its associated communication equipment in accordance with the requirements of the Albuquerque Public Schools Police Department.

- ii. All work and materials shall conform to all applicable Federal, State and Local Codes and shall be completed in accordance with good engineering practices. Materials used shall conform to current industrial standards.
- iii. **Head End:** The alarm control equipment shall be installed in a location which is reasonably secure, environmentally clean, and free of storage and away from the daily flow of traffic.
- iv. **Equipment Mounting:** All alarm control equipment shall be mounted on a 6'x8'x3/4" sheet of fire-rated plywood, unless otherwise specified, and positioned in accordance with the layout given in diagram No.1. Space shall be provided as shown in diagram No. 1, for Radio Communication Equipment, which will be installed by APSPD personnel or designee on completion of contractor specified work. A clearance distance of 12" shall be provided on the left and right of the mounting board and 36" in front of the equipment as measured from the face of the deepest box.
- v. **Configuration:** See Alarm Riser Rough-In Diagram #1
- vi. **Electrical:** The main 120 volt AC power source for the security system shall be hard wired into the alarm control equipment, encased in electrical conduit and come directly from a distribution panel which provides uninterruptible power. The circuit shall be dedicated, and be assigned its own locking handle circuit breaker. Circuit shall be identified at the breaker-panel and at the head end.
- vii. Supply 120 volt AC power and THHN wire for connection to communications equipment.
- viii. Supply ground connection #8 stranded to a ground bar kit in Enclosure D.
- ix. ENCLOSURES A & B – See Security Alarm System – Alarm Control Boxes – Diagram #2
- x. ENCLOSURES C – See Security Alarm System – Control Box Power Supplies – Diagram #3
- xi. ENCLOSURES D – See Diagram #1

4. SENSORS AND WIRING

- a. **Intrusion Sensors and Door Contacts:** Alarm circuits are closed circuit (opens on alarm). All devices in a zone shall be connected in series so that the activation of any one sensor shall cause the circuit to open. Motions and door contacts will be home run separately.
- b. **Kitchen exterior doors:** The outer door (usually a screen door) will not be switched. The inner will be switched. Hallway for each section shall be homerun back separately from classrooms/offices etc. All home runs **MUST BE LABELED at the head end** as to the area it comes from.
- c. Wall mount MW/PIR sensors are preferred. Mounting height shall be no less than seven feet, no greater than eight feet. For classrooms and offices sensor should be mounted in the corner of an outside wall looking into the room at a forty-five degree angle free of any obstruction blocking it view into the room i.e., TV mounting brackets.
- d. Industrial Wide Gap GE 1078-W door contacts are to be used. Contacts and Magnets will be silicone in place. **See Diagram #5**
- e. **Key lock boxes:** Should FMO require monitoring of these boxes, contact APS Security for information.
- f. **Wiring:** The wire used to inter-connect alarm sensors and/or door switches shall be enclosed in electrical conduit for the entire runs and shall be 4 conductors for powered sensors and 2 conductors for switch contracts.

Home run wire size shall be no less than:

- #18 AWG stranded for zone loops up to 250'
- #16 AWG stranded for zone loops up to 500'
- #14 AWG stranded for zone loops up to 750'
- #12 AWG stranded for zone loops up to 1000'

Distances shall be measured from alarm controller to the last sensor in the loop. Wiring going into the sensor to be #22 AWG stranded, this is to prevent insulation being pierced by sharp solder tips on back of PC boards.

g. **Four wire applications** (powered sensors)

Red wire used for positive DC power

Black wire used for negative DC power

White wire shall be connected continuous from alarm controller to last alarm sensor

Green wire shall be for connecting sensor contacts in series and bring the home run back to the alarm controller

h. **Two wire applications** (door switches)

Red wire shall be used for connecting the alarm sensor contact in series and bring the home run back to the alarm controller.

Black wire shall be connected continuous from the alarm controller to the last alarm sensor.

i. **Splices:** All splices shall be made with crimp on connectors or wire nut of the proper size for the number of conductors and wire size being spliced. Crimp-on spade lugs shall be used for all terminal connection to control equipment. Spade lugs will not be used in motion sensors.

5. ALARM COMMUNICATION ANTENNA

The antenna mounting location shall be with a clear unobstructed view (line of sight) of Sandia Crest.

In addition to the above the APS open end contractor shall furnish Antenna, Antenna Mount, PolyPhazer, cable and end fittings.

Antenna type to be determined by APS depending on site conditions and distance between site and Sandia Crest.

No antenna cable runs shall be over 80 feet

6. VIDEO SURVEILLANCE

Provide 1" rough in stubbed to accessible ceiling space for camera locations, consult with APS police for locations and mounting heights.

Consult with APS regarding necessity for security cameras in parking lots or other special areas (I.E. Storage sheds)

Note that most exterior cameras will need a power circuit for heaters, consult with APS

7. ACCEPTANCE

- a. Operational Check: An operational check and walk through shall be conducted by the contractor to assume that each sensor, door switch functions as described and that the entire system is working in accordance with these specifications.
- b. Physical Appearance: All screws, inspection covers, junction box covers, cover plates etc. shall be in place before final acceptance.
- c. Walk thru Inspection: Installer and APS Police Security shall conduct a walk thru inspection prior to acceptance and sign off.
- d. Design for camera locations/perimeter of building, parking lots (i.e. Pole Lights)

courtyards. Also provide camera monitoring location (viewing room, typically security office).

8. **SECURITY SYSTEM shall be in complete conduit system. ¾" minimum.**
9. HEAD END EQUIPMENT shall be located in tel/comm; with an antenna within 75' on roof.
10. MOTION DETECTORS shall be wall mount and installed in all exterior rooms with windows and doors. Corridors (but not in vestibules), within close proximity to sky lights and no higher the 8' from floor. Motion detectors shall be installed on outer walls looking in (away from windows).
11. DOOR CONTACTS shall be installed on all exterior doors and all kitchen doors and shall be flush mounted with no exposed cable.
12. SECURITY ALARM SYSTEM: Specify layout of as directed by Sound & Signal and APS Security. Specify motion detectors in all rooms with exterior windows and/or all exterior doors and specify magnetic door contracts on all solid exterior doors (typically electrical/mechanical rooms, gymnasiums, and corridors).
13. SECURITY ALARM EQUIPMENT: Refer to Standard drawings for magnetic door switch installation and wireway and boxes.
14. ACCESS CONTROL: All exterior **entry** doors, including remotely located doors with exterior hardware, shall have electronic hardware, consult with APS Security department or Sound and Signal for design. Exterior doors into electrical, mechanical and storage rooms to be keyed and is not required to have electronic hardware.
15. HEAD END The access control Equipment shall be installed in a location, which is reasonably secure, environmentally clean and free of storage.

Coordinate rough-in locations with approved APS contractor or APS security.

If any questions arise during design or construction, please contact

Michael O'Conner, APS Police

Office: (505) 830-6861

Cell: (505) 259-9993

oconner_mj@aps.edu

Tom Burson, Sound and Signal Systems

Office: (505) 884-1217

tburson@soundandsignalnm.com

Bryan Bundrant, Sound and Signal Systems

Office: (505) 884-1217

Cell: (505) 710-4648

bbundrant@soundandsignalnm.com

APPENDIX

ENCLOSURES A, B, C 24 inches x 24 inches x 6 inches. Collar Studs for mounting panels. Hoffman A242406LP

DIAGRAM #2 and DIAGRAM #3

ENCLOSURES D 15 inches x 15 inches x 8 inches.

NON-PENETRATING ROOF MOUNT ROHN #JRM23855. Mats and/or pads underneath to protect roof material. 12 Cement blocks for counter weight.

DIAGRAM #JRM and 4

Antenna: The Operating Frequency is 458.9250 Mhz. model will depend on distance to central station.

Two models used are:

Omni 450-460 MHz 5 DB Manufacture: Comscope model DB-436C

Yagi 450-470 MHz 10 DB Manufacture: PCTEL model BMYD450K

Check with APSPD Plant Security for type to be used at your location.

- X' Antenna Cable Times Wire and Cable LMR-400
- 1 "N" connector female for LMR-400 Times Wire and Cable #EZ-400-NF stock #3190-956
- 2 "N" connector male for LMR-400 Times Wire and Cable #EZ-400-NMH-D
- 1 "N" connector male for RG-58
- 1 TNC connector male for RG-58
- 1 Polyphaser IS-SON-C2
- 3 Salco 701 Processor 8 zone expander
- 3 Salco 708 Relay output 8 zones with ribbon cable
- 3 Altronix RB 1224 relay
- 3 Altronix ST1 – Snap Track
- 3 Altronix SMP3 Power supply / Charger
- 3 Universal Transformer 16.5 – 40 VA
- 3 12vdc 7AH Battery
- 3 Altronix ST3 – Snap Track
- 1 MC3 and power supply per portable zone if site has portables

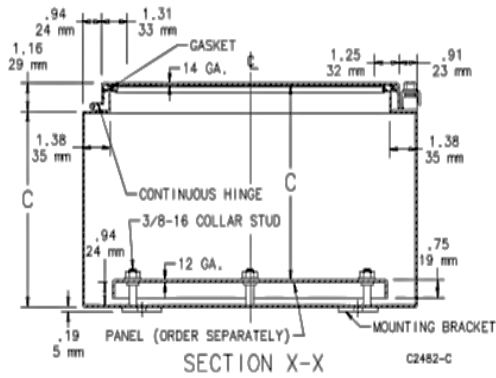
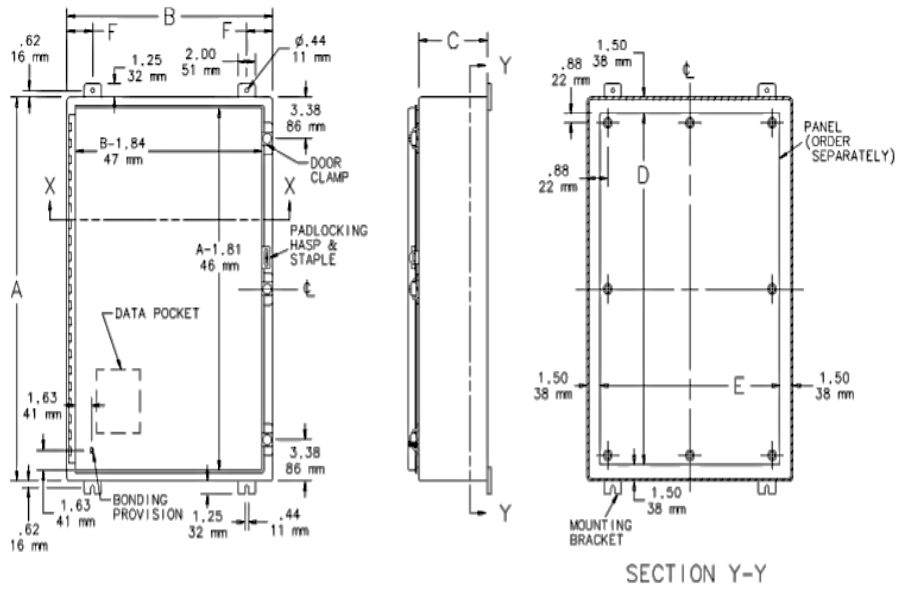

**Hoffman Catalog #A242406LP
DIAGRAM #2**

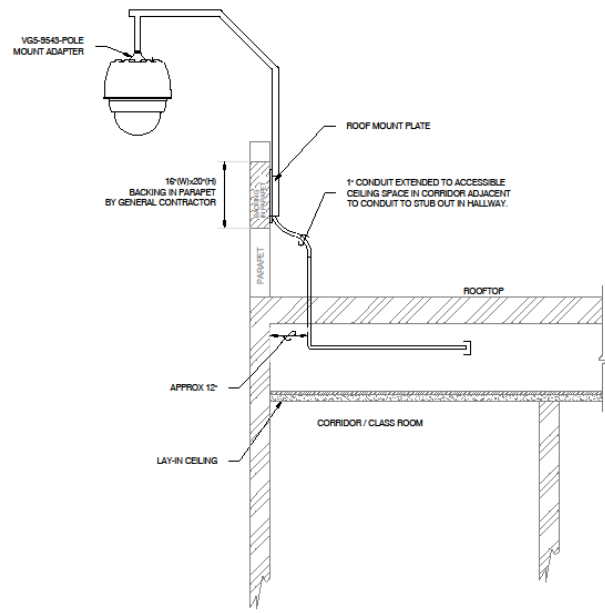

EXTERIOR CAMERA PARAPET MOUNT ROUGH-IN
NOT TO SCALE

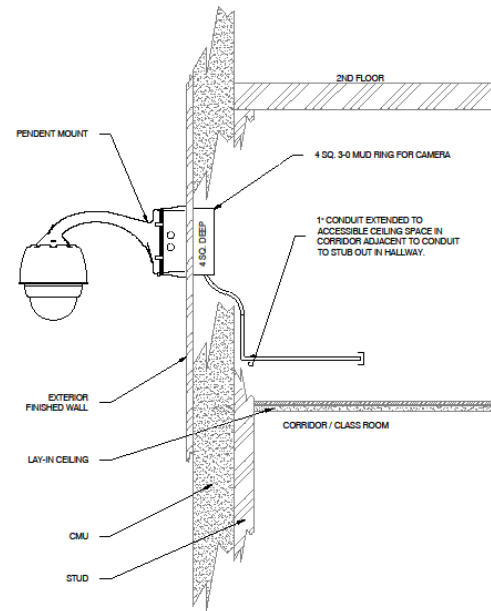

EXTERIOR CAMERA 9'-12' MOUNT ROUGH-IN
NOT TO SCALE

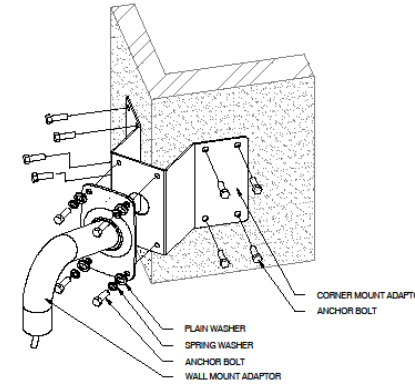

EXTERIOR CORNER MOUNT ROUGH-IN
NOT TO SCALE

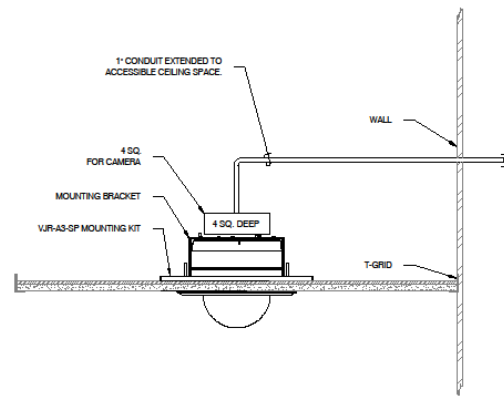

INTERIOR CEILING GRID MOUNT ROUGH-IN
NOT TO SCALE

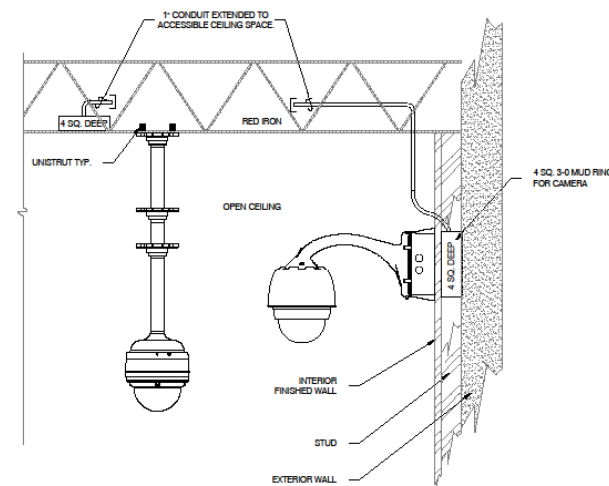

**INTERIOR OPEN CEILING
WALL & CEILING MOUNT ROUGH-IN**
NOT TO SCALE

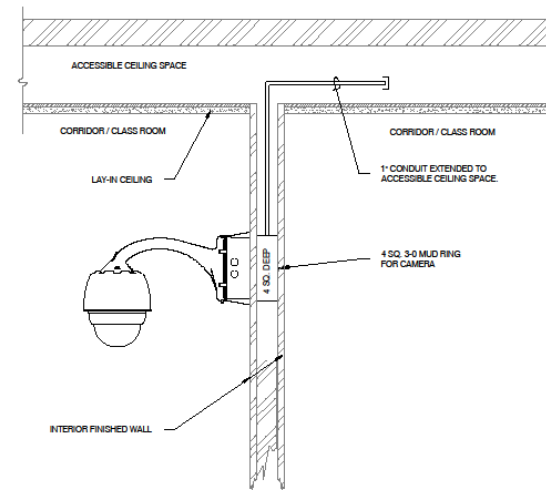

INTERIOR WALL MOUNT ROUGH-IN
NOT TO SCALE

0	04/08/15	SHOP DRAWINGS
DATE:	DESCRIPTION:	
CHECKED BY:	B.B. & B.K.	
DRAWN BY:	V.F.	
FILE NAME:	APS-ACCESS /INT. & CCTV_DETAIL	
SCALE:	NTS	

SHEET TITLE:
**CCTV
MOUNTING DETAILS**

PAGE: **TY-1**
1 OF 2

SECURITY ALARM SYSTEM – CONTROL BOX
POWER SUPPLIES

1. All simplex outlet boxes (1-6) are to be installed as shown.
2. Transformers, Power Supplies, and Batteries are to be installed as needed, in the positions as shown.

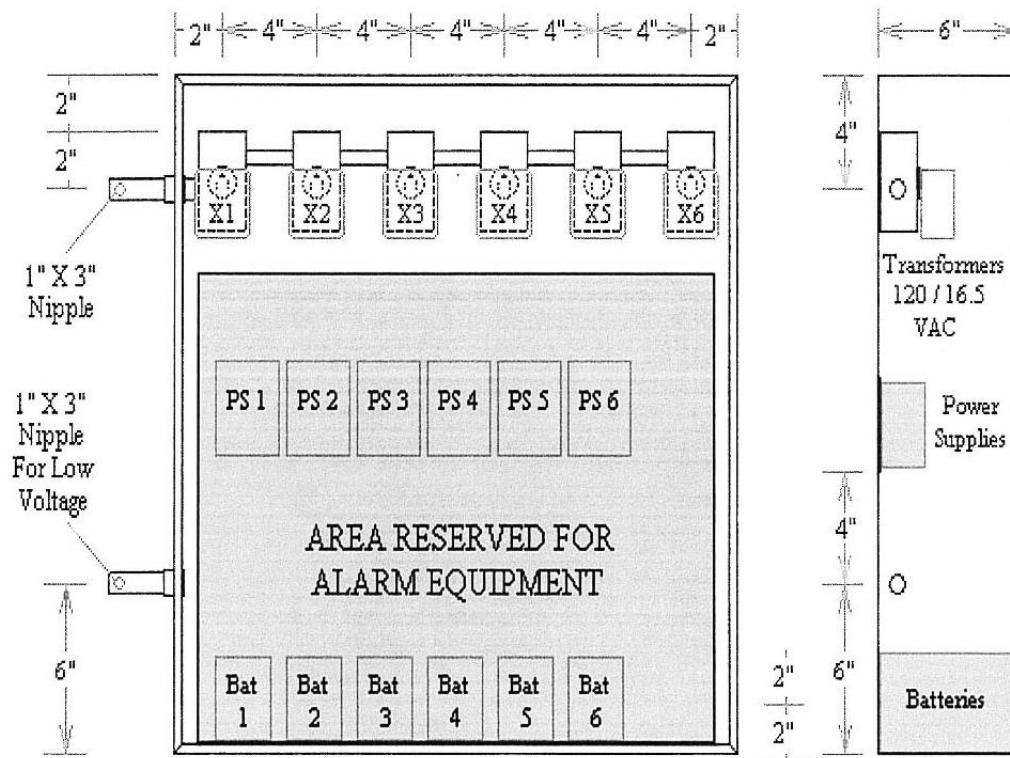
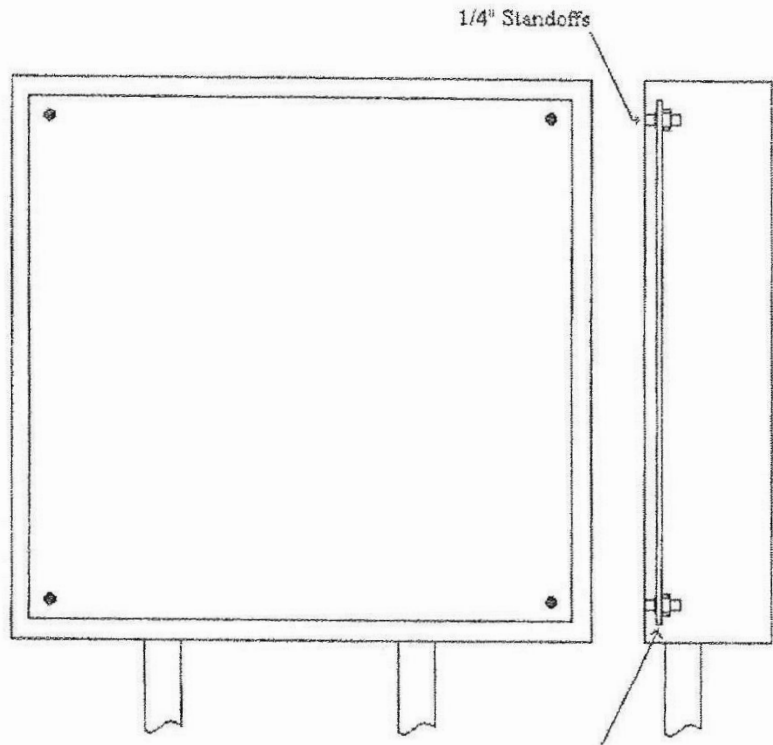

Diagram # 3

08/10

Security Alarm System
Alarm Control Boxes



Boxes "A" & "B"
Alarm Control Cans
24" X 24" X 6"

Boxes "A" & "B"
Provide removable back planes
To be installed By APS Alarm Techs

* Antennae, cableing and fittings provided by and installed by APS contractor.

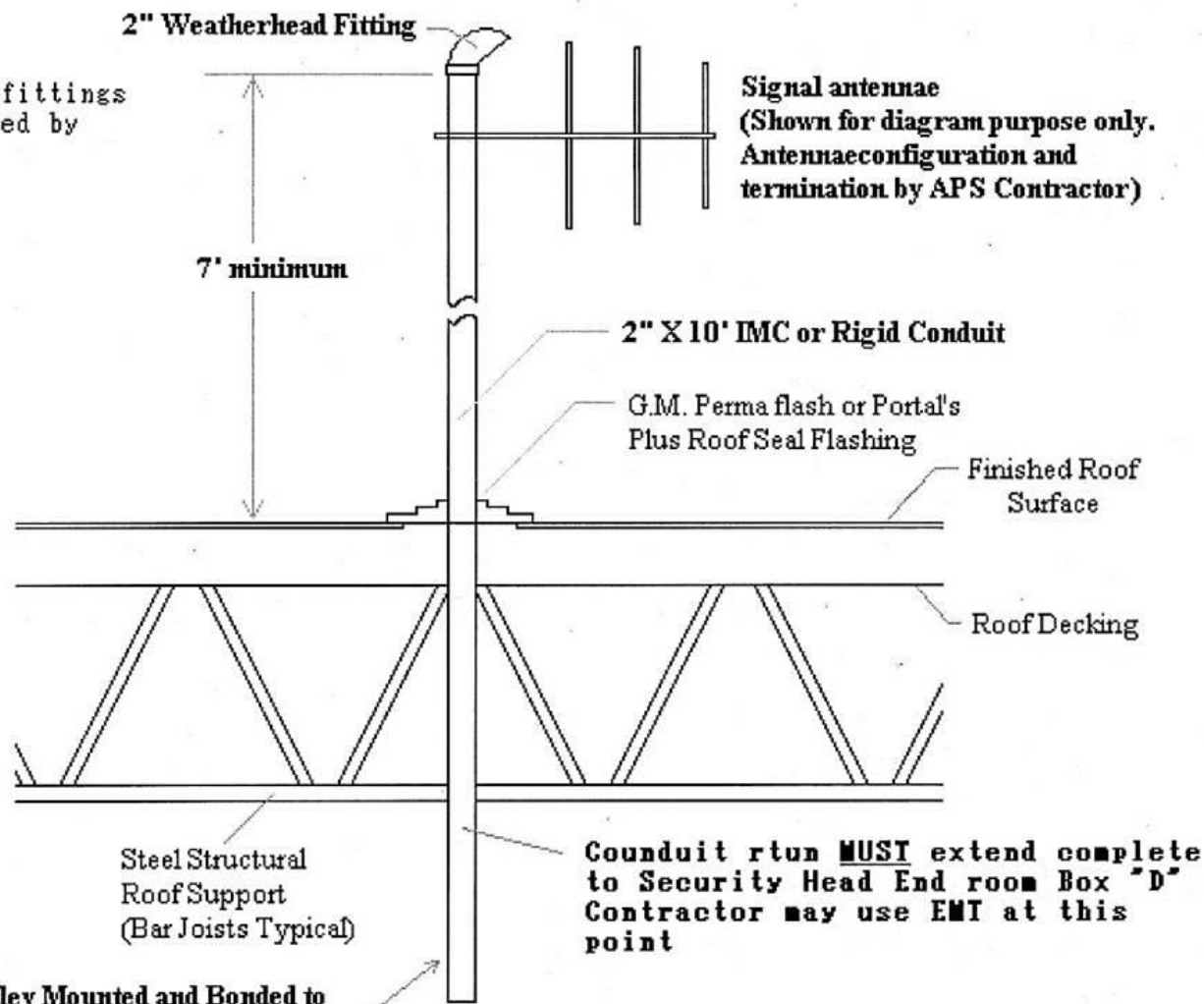

Antenna Riser Must be Securley Mounted and Bonded to the structure.
Should be able to withstand 80 MPH sustained winds.

APS Security
Antennae Detail

07/11

G. TELE & DATA COMMUNICATIONS

NOTE: Please refer to APS I.T. Department Standards for more specific detail

1. ENTRANCE FACILITY REQUIREMENTS

Provide underground, service entrances, labeled for voice, data and video service providers; Coordinate with CenturyLink for specific "Point-of-Origin" location; Provide two - 4" UG conduits and one - 2" UG conduit between service entrance box and main communications room. Conduits must be installed in separate pull boxes with traffic-rated covers, labeled "Communications". Specify 36" minimum depth, below grade, with warning tape, with long-sweep wrapped rigid metal elbows and bends. Pull string w/footage markers required. Specify PVC Schedule 40 conduit with #12 bare copper tracer wires for utility spotting.

- a. All tele and data conduit rough-in by general contractor
- b. For special systems services between buildings - 2" conduit for each of the following: fire alarm, intercom, security, data and telephones - To be ran to each building with individual 12x12x8 NEMA 3R Boxes

NOTE: Please refer to conduit color codes – Appendix A

NOTE: 2017 N.E.C. Art 314.28 for conduit entry requirements

2. MAIN COMMUNICATIONS ROOM

Design 1 – Main Communications Room per school, to include the following:

- a. Communications Room space shall be designed to facilitate all low-voltage special systems such as: voice, video, data, fire alarm, CCTV security and intercom systems and equipment, exclusively.
- b. **Minimum room sizes 12' x 14'**
- c. **9' Ceiling height minimum or No ceilings**
- d. Specify Communications Room as an interior-based room, with 36" outward-swing door. Door signage must read "**COMMUNICATIONS ROOM, NO STORAGE PERMITTED**". Consult APS for specific hardware and additional signage and nuisance buzzer requirement. All IDF and MDF rooms are to have cipher locks.
- e. Specify 3/4" AC, fire-retardant plywood on all 4 walls specified for backboards. Full Wrap. IT room to be fire rated; if painted will require fire rated paint.
NOTE: Do not paint over fire rating label.
- f. Specify an HVAC system that maintains an ambient temperature of 63 degrees F°
- g. Specify lighting that provides illumination levels for minimum 50fc, 3 ft. above floor.
- h. Specify polished concrete only.
- i. Electrical gear, transformers, mechanical equipment, piping, etc. are "**NOT**" permitted in Communications Rooms.
- j. **Specify dedicated TVSS protected 100 AMP panel for communications and electronic equipment only.**
- k. **Panel shall be shunt-trip to comply with 2017 NEC Art. 645.10. This also applies to HVAC systems supplying this room as well.**
- l. Specify dedicated 120V quadplex outlet(s), TVSS type, in all Communication Rooms and Holocombs. Coordinate with APS IT on location of outlets.
- m. Specify TVSS outlets for floor-mounted video surveillance equipment racks at 78" AFF.
- n. For wall mounted enclosures, coordinate with APS for specified TVSS outlet location and height.
- o. Specify minimum #6 bare stranded copper grounding conductor and grounding bus

bar 1”C, from the communications room backboard to the building AC electrical service ground. Grounding bus shall be 2”x18” for MDF rooms and 2”x12” for IDF rooms. Meet or exceed NEC code requirements. Ground all cable trays per latest NEC.

- p. **Specify 1-20 amp, 1-30 amp, twist-lock outlet (NEMA L5-20, L5-30P), for each voice, data and server rack. Consult with APS for specific outlet location and applicable rack quantities.**
- q. **Specify 1-20 amp Twist-lock outlet (NEMA L5-20R), for CenturyLink, TW Telcom.**
- r. Install a 4 inch conduit or ladder type cable tray from the telecom backboard to above data cabinets for power cables.
- s. Provide ladder tray around perimeter of room for special systems cabling.

3. INTERMEDIATE COMMUNICATIONS ROOMS

Design and specify one Intermediate communications room to facilitate each classroom wing and separate building. Multi-level buildings shall have one IDF Room per floor, preferably stacked. Adhere to same guideline specifications as “Main Communications Room”, with the exception of the following:

- a. Minimum IDF / TR Room Size – 10’x12’ with 9’ Ceiling
- b. Exhaust fan only – separate refrigeration not required
- c. **Specify 1-20 amp, 1-30 amp, twist-lock outlet (NEMA L5-20, L5-30P), for each voice, data and server rack. Consult with APS for specific outlet location and applicable rack quantities.**

4. CABLING PATHWAYS

Specify applicable sleeves, cable trays, stub-up conduits, homerun conduits and aerial pathways, associated with the following:

- a. Communications Rooms – Specify applicable **two** 4”C and **two** 2”C between main communications room and Intermediate communications rooms; Bushings required at each end.
- b. Corridors / Hallways – **Specify** 18” **Cablofil** basket tray, cable tray series (NO EXCEPTIONS). See Cablofil detail. All cable trays shall be grounded as per N.E.C.
- c. Sleeves – Specify applicable **two** - 2” metallic conduit sleeves at each classroom, office, gym, multi-purpose room, kitchen, similar spaces, or any room having a data outlet. Sleeves shall have enough length to be in an accessible ceiling space at both ends, and located to provide a pathway to the nearest cable-trays. Bushings required at each end. Consult with APS for all sleeve requirements and locations not already identified above.
- d. **Communications Outlets - Specify one 4 11/16 square deep box with a single-gang mud ring and a minimum 1” C, stub-up or homerun conduit per outlet.**
- e. Surface Raceways – Specify Wiremold, ivory dual-channel 5400 series, (NO EXCEPTIONS).
- f. Floor Boxes – Minimum 1.25”C; Wiremold Resources series, RFB2 or RFB4 – power/data/video. Floor Box Cover: Wiremold Floorport series – S38CCTCxx; (NO EXCEPTIONS). Floor boxes to be used only if ABSOLUTELY NECESSARY (See Receptacles and Power Section).
- g. Stub up conduits – minimum 1” C; Bushings required at stub-end.
- h. Aerial Pathways and Riser Racks – Specify 2” rigid conduit for building masts, 30’ lengths for utility poles and design riser racks applicable to APS standards. (See Pole Requirements in portables section)
- i. Design conduits for future extension with permanent marking on conduits installed

above grade. Specify PVC Schedule 40 conduit with #12 bare copper tracer wires for utility spotting.

- j. Maximum 180° conduit bends per run of conduit. Conduit runs shall **NOT** exceed 100 ft. between pull boxes.
- k. Under counter / tables: molding and or conduit is the only solution for network installations. No free air cable and or flex allowed. It's to protect the network cables from damage.

5. COMMUNICATIONS OUTLET LOCATIONS

Specify voice and data outlet locations applicable to the following:

- a. HVAC – For building automation systems, specify three (3) data drops in the location of the main DDC control panel (one for the controller itself, one for the interconnection between equipment/controller, and one for laptop internet connection). Also provide a 110V power outlet near the control device. For multi-building or multi-story applications using sub-controllers, provide one data drop at the location of each sub-controller. Coordinate data outlet location in field to be within 3 ft. of data port on equipment.
- b. Classrooms - Specify minimum of one outlet location for each voice/data outlet, per classroom wall. Locate outlets within 3' of electrical receptacles; do not locate outlets near coat racks, cubbies or water sources. Consult with APS for unique designs, such as computer labs, mini-labs, science classrooms and teacher stations.
- c. Offices - Specify two outlet locations for voice/data per office.
- d. Rough-in a data outlet anywhere a video projector, smart board, etc., is to be placed.
- e. Specify voice and data outlet locations in **ALL** electrical rooms to be located adjacent to exterior lighting time clock.
- f. Provide data/voice outlet for all copier machine locations.
- g. Computer Labs – Specify data outlet locations to accommodate up to 36 data drops. Consult with APS for specific computer lab designs, including mini-labs. 36" AFF to bottom for above-counter installations.
- h. Custodial Offices – 1 data outlet near power outlet
- i. Common Areas - for voice/data outlet locations in media centers, gymnasias, cafeterias, conference rooms, lounges and workrooms, consult with APS for specified directions.
- j. Wireless Networking – Wireless access points (WAP3) should be in a separate room or locked cage. Specify Wireless Access Point (WAP) locations as directed by APS (1 per classroom). Ceiling installation in the center of a class room is APS's standard: other facilities may vary on the placement of the WAPs: examples Gym's, Library's, Auditoriums, Cafeteria's, etc. WAP locations that are in areas with lay in ceilings will require per code to be self-supported to the ceiling deck and the WAP will be mounted to a T-Bar hanger and centered in the tile in the center of the room and supported to the red iron / I-beams and or trusses. Wall Installations can only be installed If APS IT approves the installation. For specific wireless details contact APS IT Department. (New 2015/17 requirement 1 WAP per classroom; 2 Cat6 drop per) coordinate with IT on other wireless installation requirements.
- k. **Specify analog line locations needed for FAX locations and elevators.**
- l. **1" continuous conduit from phone back board to elevator.**
- m. Kitchens/cafeteria – design data outlets for kitchen managers' office, Point of Sale locations and snack bars.

- n. Provide data outlet near lighting time clocks. Coordinate location in field to be within 3 ft. of time clock.
 - o. Provide data outlet at ALL electrical panels for M & V (2 panels – 2 outlets, 3 panels – 3 outlets, etc.). Coordinate location in field to be within 3 ft. of panels.
 - p. All exterior data drop locations shall be cast metal in-use covers
 - q. Provide a ¾ conduit and box rough-in for low voltage card reader / door operator control
 - r. Provide one – 1” conduit pathway to irrigation controller from nearest IDF room.
6. TELEVISION
Consult with APS for Television/video requirements. Specify video outlet locations applicable to the following:
- a. Common Areas - Consult with APS for specified locations regarding TV outlets in media centers, gymnasias, cafeterias, conference rooms, lounges, workrooms and foyers.
 - b. Specify Video screens (If needed) for classrooms @ +84” AFF.
7. INTERACTIVE WHITE BOARDS (IWB)
Classrooms – All classrooms to be designed for portable interactive Boards: ActivTouch 88 Mobile Adjustable is the first choice for all installations. Consult with APS IT for specifications regarding wall/ceiling mounted projectors, A/V monitors, and whiteboards. See details located in this section.
8. APS Contract Information:

VOIP/Telecom System Administrator Brian Thompson (505) 878-6101 brian.thompson@aps.edu	Enterprise Infrastructure Cabling Division IT Manager – Tony Otero (505) 830-6225 Tony.otero@aps.edu
---	---

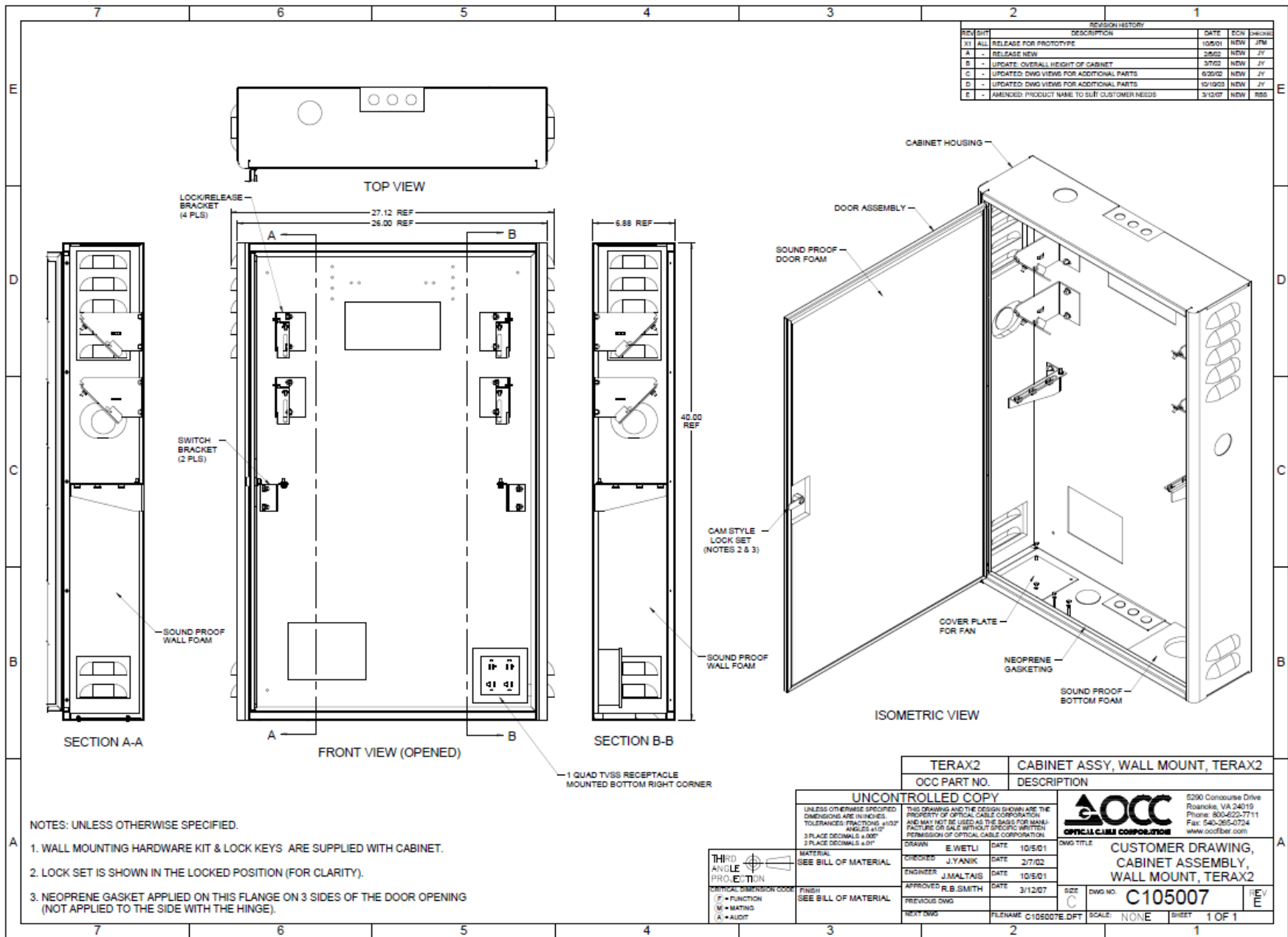

CF 54 CABLOFIL CABLE TRAY

CABLOFIL

INNOVATORS IN CABLE MANAGEMENT

8319 State Route 4
 Mascoutah IL 62258
 Phone: 800-658-4641
 618-566-3230
 Fax: 618-566-3250
www.cablofil.com

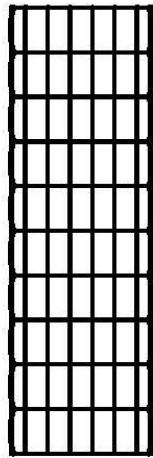

TOP

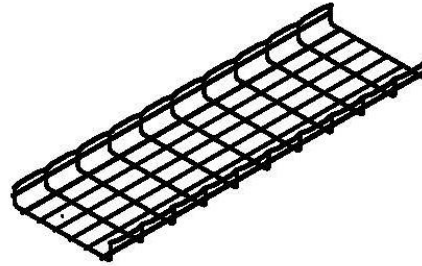

ISOMETRIC



FRONT



SIDE

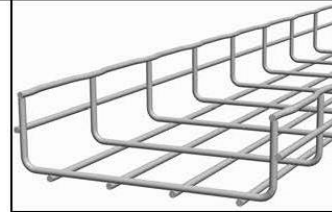
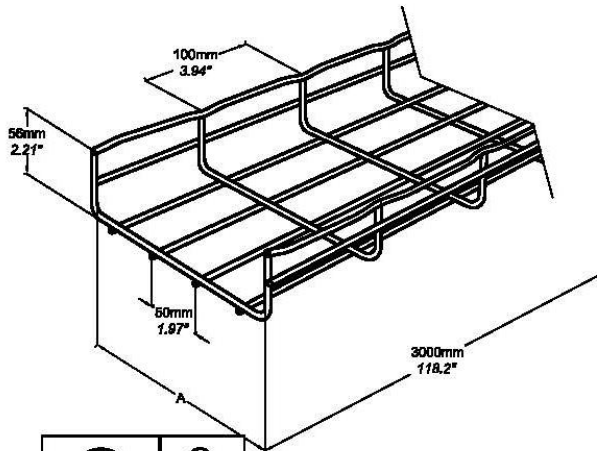

	in mm		lb
CF54 50*	1.967	50	5.3
CF54 100*	3.937	100	6.5
CF54 150*	5.904	150	7.8
CF54 200*	7.872	200	9.0
CF54 300**	11.81	300	13.4
CF54 400**	15.75	400	22.8
CF54 450**	17.71	450	25
CF54 500**	19.68	500	25.7
CF54 550**	21.65	550	28.3
CF54 600**	23.62	600	27.5



BL PE
 EZ GC 304L 316L

	Material	Finish
EZ	Carbon Steel ASTM A510 Grade 1008	Electroplated Zinc, ASTM B633
GC	Carbon Steel ASTM A510 Grade 1008	Hot-Dip Galvanized ASTM A123
BL	Carbon Steel ASTM A510 Grade 1008	Black Painted ASTM D 3451
PE	Carbon Steel ASTM A510 Grade 1008	Custom Painted ASTM D 3451
304L	AISI TYPE 304L	Passivated ASTM A 380
316L	AISI TYPE 316L	Passivated ASTM A 380

Copyright © 2005 Cablofil, Inc. Max wire diameter is 5.9mm. Sizes and Quantity vary by tray size. CABCS0052 US PAT# 6138961

FAS PCH CENTER HANGER

CABLOFIL®

INNOVATORS IN CABLE MANAGEMENT

8319 State Route 4
 Mascoutah IL 62258
 Phone: 800-658-4641
 618-566-3230
 Fax: 618-566-3250
 www.cablofil.com



TOP

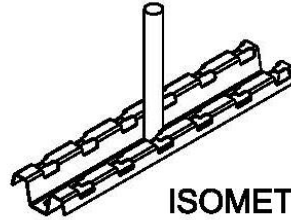

ISOMETRIC

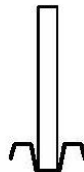

SIDE

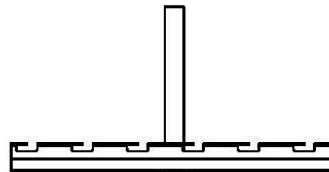

FRONT

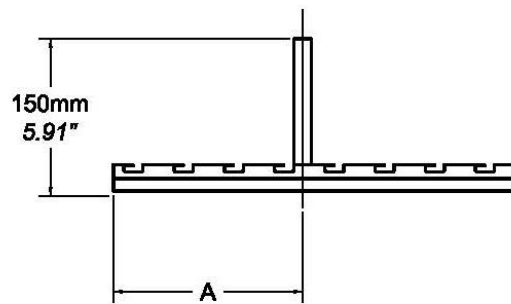
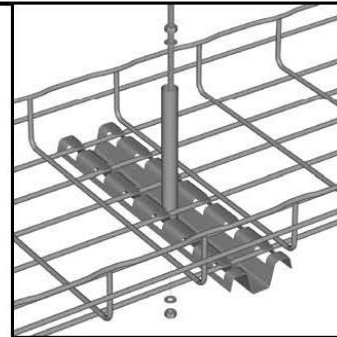
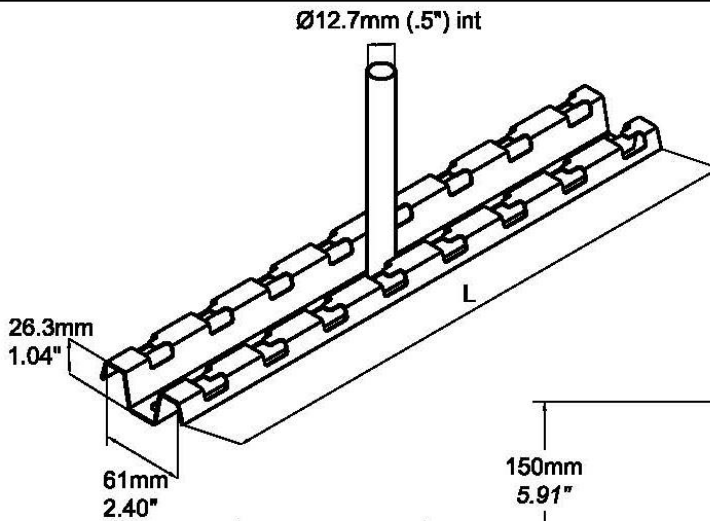

	L		A		lb
	in	mm	in	mm	
FASPCH 150	5.87	154	2.13	54	0.45
FASPCH 200	7.64	194	4.09	104	0.63
FASPCH 300	11.57	294	6.06	154	0.89
FASPCH 400	15.51	394	8.03	204	1.15
FASPCH 450	17.48	444	8.03	204	1.28
FASPCH 500	19.45	494	10.00	254	1.41
FASPCH 600	23.39	594	11.97	304	1.67

PG GC 316L BL PE

Copyright©2005 Cablofil, Inc.

CABCS0364

H. ENERGY CONSERVATION

1. Specify “Energy Star” rated appliances and equipment where applicable.
2. Perform Lighting Power Density Calculations and certify that lighting energy complies with ASHRAE 90.1. Make these calculations available for utility rebate and LEED submissions.
3. Specify energy efficient lamp sources. Refer to the Interior Lighting section for additional information. In general, use LED type lamps, interior and exterior.
4. Design dimming or dual level switching (inner/outer lamps) for all 2x4 troffers and indirect fixtures.
5. Design occupancy/vacancy sensors for control of lighting in restrooms, janitor closets, teacher’s lounge, classrooms, and offices. The engineer shall review rooms to have occupancy sensors with APS during the 50% review meeting. All occupancy/vacancy sensors shall have an “auto-off” switch on the line side of the device. Hands-off-automatic device (e.g., Leviton 1221-2L) in areas where students are commonly present and multi stall adult restrooms controlled with ceiling mounted sensor. **See Interior Lighting Section.**
6. Specify separate switching/dimming fixtures adjacent to windows separately, (only where applicable or where approved by APS).
7. Coordinate with mechanical for building automation system, time clocks and control diagrams for HVAC systems.
8. Design toilet exhaust fans to be switched with lighting in restrooms (on occupancy sensors). If relays are required, locate in accessible location.
9. Design exterior lighting to be controlled from electronic time clocks with “astronomical” feature and design each clock with two or more circuits. Refer to the “Site Electrical” section for additional information.
10. Group sections of light fixtures for large spaces in banks and switch locally by zones of lighting. Discuss in specific detail with APS during preliminary design meetings.
11. Solar photovoltaic systems shall be comprised fixed solar panels, tied to electric utility grid with separate PV system metering/monitoring capability, and shall include comprehensive trainings. **NOTE 2017 N.E.C. Article 705, and N.E.C. Article 690 for important N.E.C. requirements regarding installation of Solar P.V. Arrays.**

See Solar PV Guidelines on APS FD & C website:

<http://www.aps.edu/facilities-design-and-construction/design-standards-and-guidelines>

I. STANDBY ENGINE GENERATORS

1. Submit computer calculations for standby engine generator sizing.
2. Design for proper clearances for maintenance and correct operation of the standby engine generator (no air flow restrictions and adequate air circulation and ventilation).
3. Design shall include separate 1" C with control wires, as required, from the SEG control panel and the ATS to the standby engine generator.
4. Specify dedicated 120 volt or 208V (single phase) branch circuit from the SEG to the emergency power panel for the crankcase heater.
5. Specify SEG muffler to be "critical silence" type.
6. Coordinate intake and/or exhaust louver sizes and muffler piping with mechanical engineer.
7. Design interlocks wiring from the auxiliary contact in the SEG ATS to exhaust louvers and exhaust fan.
8. Coordinate with mechanical engineer for exhaust manifold piping from the SEG to the exterior of the building.
9. Specify oil drip pan located beneath the frame of the SEG.
10. Specify options for all SEG installations:
 - a. On-Set SEG circuit breaker.
 - b. Weather-protective housing (where the SEG is located on the exterior of the building).
 - c. Water jacket heater (exterior applications) and power wiring.
 - d. Critical silence muffler.
 - e. Remote Annunciator Panel
 - f. Specify for the Contractor to provide three (3) sets of O&M manuals
 - g. SEG shall be diesel fueled (#2)

J. RENOVATION & RE-ROOFING

Before beginning any roofing work, conduct a walkthrough with an Owner's representative to document the operating condition of rooftop HVAC equipment and exterior lighting circuits. At the completion of roofing work, conduct and document a second walkthrough with an Owner's representative to demonstrate all equipment is in pre-construction or better condition.

1. RENOVATION PROJECTS:

- a. Discuss electrical service upgrades with APS FD&C / M&O and coordinate field engineering meeting with APS FD&C / M&O personnel.
- b. Discuss electrical issues with the School Principal and Custodial Staff and implement correction of re-occurring electrical problems (within scope of work) into the electrical construction documents.
- c. Document and provide electrical removal drawings indicating specific removal of electrical and/or relocation of lighting and devices.
- d. Meet with the APS Open-End Special Systems Contractors and provide coordination and design relative to the Sound/PA System, Fire Alarm System, the Security Alarm System, and Telecommunications (Voice and Data). Document and design relative to upgrades, junction box and conduit interface between existing panels and new panels.
- e. Design details conduit routing between existing special system cabinet (Fire Alarm, Security Alarm, Sound/PA, and Telecommunications) in the existing building and new cabinets in the new building addition (where required).
- f. Where conduits are installed on the roof, they shall be specified IMC/Rigid Conduit. Routing of new conduits on the roof shall be coordinated with existing equipment and shall be installed on adjustable support racks.
- g. Check with APS for existing roof warranty which will dictate proper penetration and sealing methods.
- h. **Existing 'Down Stream' circuitry shall be maintained and/or re-fed if originating or passing through remodel scope.**
- i. All abandoned circuits and conduits shall be removed

2. REROOFING PROJECT:

- a. Meet with the APS Open-End Special Systems Contractors and provide coordination and design relative to the Sound/PA System, Fire Alarm System, the Security Alarm System and Telecommunications (Voice and Data), Document and design a junction box and conduit system for removal of boxes and conduits on the roof and installation of new boxes and conduits.
- b. Design detailed power wiring for new HVAC equipment on the roof. Conduit may be installed within the roof system. Conduit systems within roof system shall be IMC/rigid only, See Conduit Methods for On/In Roof-2014 N.E.C. Art. 300.4 (E). IMC; rigid conduit shall be used for all exposed conduit runs. No exposed conduit on the roof, unless otherwise approved by APS. Install 20A GFI receptacle at new rooftop HVAC equipment or within 25' of HVAC equipment (NEC 2014, 210.63), Coordinate with APS for direction before adding receptacles at existing rooftop HVAC equipment.
- c. Provide standard roofing details for conduit penetrations through the new roof and new conduit support racks. Coordinate with APS for use of standards details.
- d. Coordinate electrical installations with the Roofing Specifications.
- e. Add a general note to the electrical drawings as follows:
"THE CONTRACTOR SHALL PERFORM ALL DISCONNECTS, EXTENSIONS, RECONNECTS, ETC. FOR ALL EXISTING ROOFTOP AND HVAC EQUIPMENT, INCLUDING ELECTRICAL CONDUIT AND BOXES, AS NECESSARY TO

ACCOMMODATE THE NEW TOTAL THICKNESS OF THE NEW ROOFING SYSTEM WITH CLEARANCES AS REQUIRED.”

3. GENERAL:

- a. Install roofing slip sheet underneath all support and should extend minimum 4” beyond support footprint.
- b. No wood supports shall be used for any equipment.
- c. All penetrations shall extend minimum 8” above finished roof system.



B-Line's C-Port Rooftop Support Solution

COOPER CONNECTION SEARCH COOPER INDUSTRIES COOPER INDUSTRIES HOME COOPER

Search Products (Select Search Type) -->

What's New



HOME ABOUT US WHAT'S NEW PRODUCTS LIBRARY DESIGN CENTER SERVICES EMPLOYMENT CONTACT US SEARCH

What's New

- [Complete News Listing](#)
- [New Literature](#)
- [News By Product Line](#)
- [Press Releases](#)
-
- [Events Calendar](#)
- [Newsletters & Bulletins](#)

B-Line's C-Port: A Complete Rooftop Support Solution

B-Line C-Port components with B-Line Strut and Pipe Hanger Systems offer a total solution for roof tops and more...



Features:

- Compatible with most all rooftop materials
- Extends Roof Life
- Dampens Vibrations
- No Need For Supplemental Rubber Pad
- Will Not Float
- Supports 2500 Lbs./ft.*
- Made from 100% Recycled Rubber

Innovative, economical roof top support systems for use as:

- Pipe Supports
- HVAC Supports
- Roof Walkway Supports
- Duct Supports
- Conduit Supports
- Underfloor applications



B-Line C-Port Rooftop Support System

CX-Series

Specifications:
Base Only
Dimensions - 4" High x 6" Wide x 9.6" Long (base length)
Material - 100% recycled rubber, UV resistant
Maximum Load - 500 lbs./ft.* (Uniform load)



C-Port CX-Series channel support is designed as an economical support for gas piping systems, cable tray, HVAC equipment and many other applications. The C-Port is UV resistant and approved for any type of roofing material or other flat surfaces. Material effectively accepts screw fasteners for securing one (1) or two (2) hole straps (not included).

Cat. No.	Height	Width	Length	Weight Ea.
CXP	4" (101mm)	6" (152mm)	9.6" (244mm)	4.86 Lbs. (2.20kg)

C-Series

K. INFRASTRUCTURE FOR PORTABLES

1. All electrical utilities to the Portable racks shall be designed underground from the school to the respective portable racks (power and telecommunications and other special systems) with overhead or underground distribution from the racks to the portables. (See details)
2. All electrical enclosures mounted at the portable racks shall be designed as NEMA 4 (no exceptions).
3. All electrical distribution from the portable racks to the portables shall be designed as “star” distribution (avoid loop from portable to portable).
4. The design of electrical systems shall be discussed with APS during the design development phase of the project and direction will be given to the engineer regarding location of the portable rack and distribution from the portable racks to the portables.
5. Electrical power for the portables shall be derived from the school’s electrical distribution system. Do not provide separate metering from an alternate power source, unless absolutely necessary and specifically approved by APS FD&C and M&O.
6. During the Design Development phase of the design project, coordinate with the Architect and review the School’s Master Plan for location of the proposed portable park.
7. Research and coordinate with the City of Albuquerque Building Department for issues related to electrical grounding, bonding, and load calculations and sizing of the electrical service at portables. Document in writing all items discussed, secure a signature from the City of Albuquerque Building Electrical Department and send the letter to the Architect. Quadplex feeders with isolated neutral and ground rods at each building.
8. Design conduits for the following special systems:
 - a. 2” conduit with pull string from the MDF and/or IDF Room to the Data terminal cabinet at the portable rack.
 - b. 2” conduit with pull string from the MDF or IDF Room telephone backboard to the Telephone terminal cabinet at the portable rack.
 - c. 1” conduit with pull string from the closest fire alarm terminal cabinet to the fire alarm terminal cabinet at the portable rack.
 - d. 2” conduit with pull string from the closest Sound/PA terminal cabinet to the Sound/PA system terminal cabinet at the portable rack.
 - e. 1” conduit with pull string from the closest Security Alarm terminal cabinet to the Security Alarm terminal cabinet at the portable rack.
9. All wooden support poles shall be 30 feet length minimum with 5 feet bury depth.
10. Green-Pressure treated wooden poles are not allowed. Brown creosote poles preferred.
11. REFERENCE: PENTACHLOROPHENOL TREATED WOOD POLES
12. 30’ and 35’ Class 3 Douglas Fir peeled poles produced and fabricated in accordance with ANSI specification 05.1. The poles will be full length pressure treated to a net retention of 0.60# per cubic foot of wood for Douglas-Fir, using Pentachlorophenol.
13. All poles shall be blank poles.

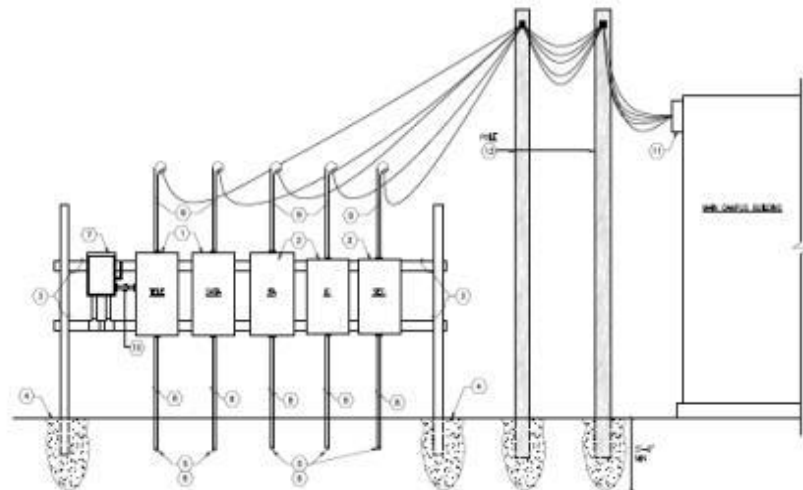

PORTABLE BUILDING SPECIAL SYSTEMS RISER DIAGRAM (OVERHEAD TO UNDERGROUND)
NO SCALE

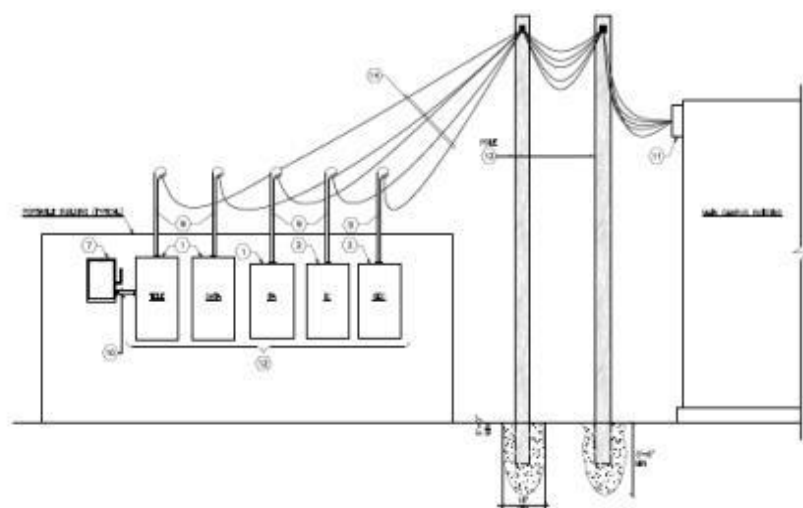

PORTABLE BUILDING SPECIAL SYSTEMS RISER DIAGRAM (OVERHEAD)
NO SCALE

GENERAL NOTES

1. ALL TRENCH COVERS AND SLOPE DITCHES SHALL COMPLY WITH STATE DEPT. AND SHALL BE INSTALLED IN ACCORDANCE WITH THE FOLLOWING:

KEYED NOTES

1. 2" PVC RIGID RISER SHALL BE INSTALLED IN ACCORDANCE WITH THE FOLLOWING:
2. 2" PVC RIGID RISER SHALL BE INSTALLED IN ACCORDANCE WITH THE FOLLOWING:
3. 2" PVC RIGID RISER SHALL BE INSTALLED IN ACCORDANCE WITH THE FOLLOWING:
4. 2" PVC RIGID RISER SHALL BE INSTALLED IN ACCORDANCE WITH THE FOLLOWING:
5. 2" PVC RIGID RISER SHALL BE INSTALLED IN ACCORDANCE WITH THE FOLLOWING:
6. 2" PVC RIGID RISER SHALL BE INSTALLED IN ACCORDANCE WITH THE FOLLOWING:
7. 2" PVC RIGID RISER SHALL BE INSTALLED IN ACCORDANCE WITH THE FOLLOWING:
8. 2" PVC RIGID RISER SHALL BE INSTALLED IN ACCORDANCE WITH THE FOLLOWING:
9. 2" PVC RIGID RISER SHALL BE INSTALLED IN ACCORDANCE WITH THE FOLLOWING:
10. 2" PVC RIGID RISER SHALL BE INSTALLED IN ACCORDANCE WITH THE FOLLOWING:
11. 2" PVC RIGID RISER SHALL BE INSTALLED IN ACCORDANCE WITH THE FOLLOWING:
12. 2" PVC RIGID RISER SHALL BE INSTALLED IN ACCORDANCE WITH THE FOLLOWING:
13. 2" PVC RIGID RISER SHALL BE INSTALLED IN ACCORDANCE WITH THE FOLLOWING:
14. 2" PVC RIGID RISER SHALL BE INSTALLED IN ACCORDANCE WITH THE FOLLOWING:

CONDUIT SCHEDULE			
TRADE	CONDUIT	TYPE	SIZE
1	2"	PVC	RIGID
2	2"	PVC	RIGID
3	2"	PVC	RIGID
4	2"	PVC	RIGID



ALBUQUERQUE
PUBLIC SCHOOLS
PORTABLE BUILDING
STANDARD DRAWING

DATE	BY	CHKD BY

SPECIAL SYSTEMS
RISER DIAGRAMS

HEET NO.
E-201

LOAD SUMMARY-DOUBLE PORTABLE	
DESCRIPTION (SAMPLE) WITH DWP COOLER	
DOUBLE PORTABLE ESTIMATED DEMAND PER NEC 220	
MEDICAL UNITS (2.3 KVA COOH)	2.3 KVA
(DWP COOLER) 1 HP	
RECEPTACLES (2.8 KVA COOH)	2.8 KVA
FIRST 10 KVA AT 100% REMAINDER AT 50%	
LIGHTING (2.2 KVA COOH) AT 100%	2.2 KVA
EQUIPMENT (0.5 KVA COOH) AT 100%	0.5 KVA
TOTAL ESTIMATED LOAD:	7.8 KVA
32.5 AMPERES AT 120/240V-1P-3W	
MINIMUM SERVICE CAPACITY = 125% x TOTAL ESTIMATED LOAD	9.7 KVA
40.4 AMPERES AT 120/240V-1P-3W	
MINIMUM RECOMMENDED SERVICE SIZE =	40 AMPS

LOAD SUMMARY-DOUBLE PORTABLE	
DESCRIPTION (SAMPLE) WITH REFRIGERATED AIR	
DOUBLE PORTABLE ESTIMATED DEMAND PER NEC 220	
MEDICAL UNITS (8.9 KVA COOH)	8.9 KVA
(REFRIGERATED AIR)	
RECEPTACLES (2.8 KVA COOH)	2.8 KVA
FIRST 10 KVA AT 100% REMAINDER AT 50%	
LIGHTING (2.2 KVA COOH) AT 100%	2.2 KVA
EQUIPMENT (0.5 KVA COOH) AT 100%	0.5 KVA
TOTAL ESTIMATED LOAD:	12.4 KVA
51.6 AMPERES AT 120/240V-1P-3W	
MINIMUM SERVICE CAPACITY = 125% x TOTAL ESTIMATED LOAD	15.5 KVA
64.5 AMPERES AT 120/240V-1P-3W	
MINIMUM RECOMMENDED SERVICE SIZE =	100 AMPS

LOAD SUMMARY-SINGLE PORTABLE	
DESCRIPTION (SAMPLE) WITH DWP COOLER	
SINGLE PORTABLE ESTIMATED DEMAND PER NEC 220	
MEDICAL UNITS (1.1 KVA COOH)	1.1 KVA
(DWP COOLER) 1/2 HP	
RECEPTACLES (1.4 KVA COOH)	1.4 KVA
FIRST 10 KVA AT 100% REMAINDER AT 50%	
LIGHTING (1.2 KVA COOH) AT 100%	1.2 KVA
EQUIPMENT (0.5 KVA COOH) AT 100%	0.5 KVA
TOTAL ESTIMATED LOAD:	4.2 KVA
17.5 AMPERES AT 120/240V-1P-3W	
MINIMUM SERVICE CAPACITY = 125% x TOTAL ESTIMATED LOAD	5.3 KVA
22.0 AMPERES AT 120/240V-1P-3W	
MINIMUM RECOMMENDED SERVICE SIZE =	30 AMPS

LOAD SUMMARY-SINGLE PORTABLE	
DESCRIPTION (SAMPLE) WITH REFRIGERATED AIR	
SINGLE PORTABLE ESTIMATED DEMAND PER NEC 220	
MEDICAL UNITS (3.3 KVA COOH)	3.3 KVA
(REFRIGERATED AIR)	
RECEPTACLES (1.4 KVA COOH)	1.4 KVA
FIRST 10 KVA AT 100% REMAINDER AT 50%	
LIGHTING (2.2 KVA COOH) AT 100%	2.2 KVA
EQUIPMENT (0.5 KVA COOH) AT 100%	0.5 KVA
TOTAL ESTIMATED LOAD:	6.4 KVA
26.6 AMPERES AT 120/240V-1P-3W	
MINIMUM SERVICE CAPACITY = 125% x TOTAL ESTIMATED LOAD	8.0 KVA
33.0 AMPERES AT 120/240V-1P-3W	
MINIMUM RECOMMENDED SERVICE SIZE =	40 AMPS

GENERAL NOTES

A. ALL SERVICE CONDUITS AND SERVICE ENTRANCES SHALL CONTAIN TWO LARGE SHEEPS AND SHALL BE WAPPED OR DAPED FOR CORROSION PROTECTION.

KEYED NOTES

1. GALVANIZED UPRIGHT RACK, 1 1/2" (DOUBLE) RACK SIZE LOCATION AS DESIGNATED BY A.P.S.
2. 3" MINIMUM CONCRETE BASE.
3. 90° ELBOWS (RAC), ELBOW TO BE LARGE SHEEPS.
4. 30 AMP SINGLE PHASE DISCONNECT SWITCH FOR SPECIAL SYSTEMS CABINET, HAVE REQUIRES CONNECTIONS COORDINATE WITH BOARD AND DRAW.
5. DISTRIBUTION PANEL, REFER TO PANEL SCHEDULE THIS SHEET.
6. 3 #12 IN A 1/2" CONDUIT.
7. METER ENCLOSURE PER PWA REQUIREMENTS AND A.P.S. M&O DEPARTMENT APPROVED FOR ALTERNATE POWER SOURCE.
8. RAC CONDUIT WITH RIGID ELBOWS AND RESER. SIZE OF CONDUIT AND CONDUCTORS BASED ON PWA/BOARD APPROVE.
9. CONDUIT AND WEATHERHEAD ASSEMBLY AND STAND-OFF BRACKETS PER PWA REQUIREMENTS.
10. AMPERAGE BASED ON TOTAL LOAD OF PORTABLES SERVED.
11. GROUNDING PER REC. REFER TO GROUNDING DIAGRAM.
12. SERVICE CONDUIT AND CONDUCTORS UNDERGROUND TO PORTABLE BUILDINGS FROM DISTRIBUTION PANEL.
13. MAIN SERVICE CONDUIT AND CONDUCTORS.
14. MAIN SERVICE DISCONNECT SWITCH, FURNISHED WITH PORTABLE BUILDING.
15. METAL SERVICE CONDUIT AND ASSOCIATED WEATHERHEAD.
16. METAL SERVICE CONDUCTORS SERVING PORTABLE BUILDING RACK USUALLY #2 DUAL-FLEX CONDUCTORS.
17. BRANCH CIRCUIT BREAKER SERVING PORTABLE FROM MAIN DISTRIBUTION PANEL IN MAIN SCHOOL BUILDING.
18. 30 FEET LENGTH (MIN) WITH 8 FEET BURIED DEPTH. (BROWN CIRCLED)
19. LOADS SHALL BE BALANCED ON ALL "PHASES" AS MUCH AS POSSIBLE.
20. NUMBER OF SPACES AS REQUIRED TO SERVE QUANTITY OF PORTABLES AT SITE LOCATION.
21. OVERHEAD SERVICE CONDUCTOR CLEARANCES SHALL COMPLY WITH REC. SECTION 230.2.4.
22. SEPARATE METER IF REQUESTED AND/OR REQUIRED BY A.P.S. M&O DEPARTMENT.
23. DUAL-FLEX CONDUCTORS TO PORTABLES SHALL BE TWO (2) INSULATED PHASE CONDUCTORS AND ONE (1) NEUTRAL CONDUCTOR SHALL BE THE NEUTRAL AND IDENTIFIED PER REC. ARTICLE 200.4 WITH STEEL WEATHER/OBJECT CABLE USING A GROUNDING CONDUCTOR. GROUNDING SHALL BE PER REC. ARTICLE 250.

SAMPLE

PANEL: MAIN 3R		VOLTAGE: 120/240V-1P-3W		MANS: 400A		AIC: 10,000	
SOURCE: (10)		SWITCH: 3/4" FEED BOTTOM		MAIN BREAKER: 400A/3P		MOUNTING SURFACE	
DESCRIPTION	BREAKER	LOAD (VA)	CT NO.	LOAD (VA)	CT NO.	LOAD (VA)	CT NO.
PORTABLES	100A 3P	8748	1	15448	2	7200	100A 3P
PORTABLES	20	8748	3	15448	4	7200	3P
PORTABLES	100A 3P	8748	5	15448	6	8499	100A 3P
PORTABLES	20	8748	7	15448	8	8499	3P
SPECIAL SYSTEMS	20A 1P	0	9	0	10	0	1P SPACE ONLY
SPACE ONLY	1P	0	11	0	12	0	1P SPACE ONLY
SPACE ONLY	1P	0	13	0	14	0	1P SPACE ONLY
SPACE ONLY	1P	0	15	0	16	0	1P SPACE ONLY
SPACE ONLY	1P	0	17	0	18	0	1P SPACE ONLY
TOTAL LOAD (VA)		32930		15948		16932	
TOTAL CONNECTED (KVA): 85.9		ESTIMATED DEMAND (KVA):					

NOTE: ENGINEER WILL BE RESPONSIBLE FOR PROVIDING VOLTAGE DROP CALCULATIONS AS REQUIRED BY AUTHORITY HAVING JURISDICTION.

SAMPLE

PANEL: (FROM 3R)		VOLTAGE: 120/240V-1P-3W		MANS: 400A		AIC: 10,000	
SOURCE: (10)		SWITCH: 3/4" FEED BOTTOM		MAIN BREAKER: 250A/3P		MOUNTING SURFACE	
DESCRIPTION	BREAKER	LOAD (VA)	CT NO.	LOAD (VA)	CT NO.	LOAD (VA)	CT NO.
PORTABLES	100A 3P	8748	1	15448	2	7200	100A 3P
PORTABLES	20	8748	3	15448	4	7200	3P
PORTABLES	100A 3P	8748	5	15448	6	8499	100A 3P
PORTABLES	20	8748	7	15448	8	8499	3P
SPACE ONLY	1P	0	9	0	10	0	1P SPACE ONLY
SPACE ONLY	1P	0	11	0	12	0	1P SPACE ONLY
SPACE ONLY	1P	0	13	0	14	0	1P SPACE ONLY
SPACE ONLY	1P	0	15	0	16	0	1P SPACE ONLY
SPACE ONLY	1P	0	17	0	18	0	1P SPACE ONLY
TOTAL LOAD (VA)		28444		12444		13444	
TOTAL CONNECTED (KVA): 48.9		ESTIMATED DEMAND (KVA):					

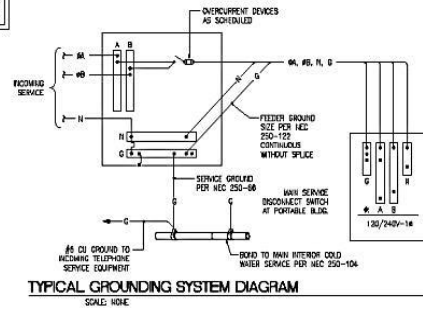

TYPICAL GROUNDING SYSTEM DIAGRAM
SCALE: NONE

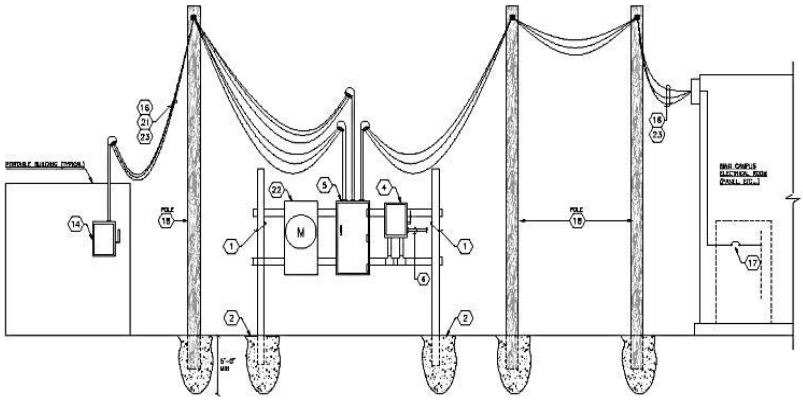

PORTABLE BUILDING POWER RISER DIAGRAM (OVERHEAD) (SCHOOL ELECTRICAL DISTRIBUTION SYSTEM)
NO SCALE

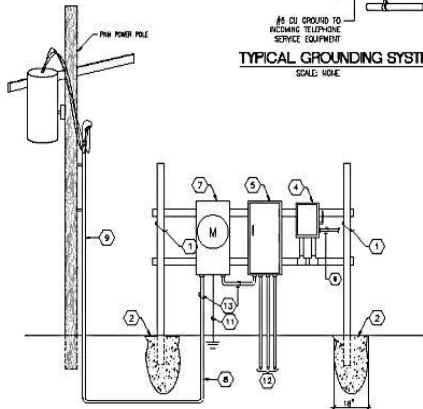

PORTABLE BUILDING POWER RISER DIAGRAM (OVERHEAD TO UNDERGROUND) (FROM ALTERNATE SOURCE)
NO SCALE

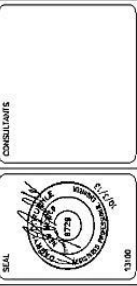
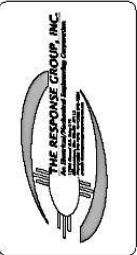

ALBUQUERQUE PUBLIC SCHOOLS
PORTABLE BUILDING
STANDARD DRAWING

DATE:	
DESCRIPTION:	
MARK:	
PROJECT NO.:	
DESIGNED BY:	RP
DRAWN BY:	JND
CHECKED BY:	DRP
DATE:	MAY 30, 2013

SHEET TITLE
**POWER RISER
DIAGRAMS, PANEL
SCHEDULE & LOAD
SUMMARIES**

SHEET NO:
E-202
of

L. MISCELLANEOUS

NOTE: Numbers 1. and 2., apply to all installations, including electrical feeders and branch circuits, as well as **ALL** special systems feeders and branch circuits.

1. Electrical portion of plans shall include a note to reference Mechanical Pages for Electrical requirements, equipment and circuitry.
2. All conduit systems installed in concrete (this does not include lite weight roof concrete – see Re-Roofing Section) and underground shall be PVC.
3. Old, used, and not salvaged fluorescent lamps and ballasts shall be disposed of properly and in accordance to current and applicable environmental regulations.
4. All bends of 60° or greater in concrete (including lite weight roof concrete) or underground installations shall be wrapped/plastic coated RIGID METAL CONDUIT.
5. All underground raceways shall have a warning tape placed at least 6” above conduit.
6. PVC conduit shall not be used in exposed locations, regardless of interior or exterior EMT, IMC, or rigid metal conduit shall be used for exposed locations.
7. For exterior or damp/wet locations, metallic core sealtight flex shall be used, with metallic fittings. No plastic fittings or flex.
8. No aluminum flexible conduit shall be used, steel flex only.
9. Type ENT Raceway Systems are strictly prohibited on any APS Project.
10. MC Cable only #12 minimum **NO AC CABLE!**
11. Flex/MC Cable runs shall be used for light fixture whips, where EMT rigid conduit is not practical, and for vibration producing equipment. Flex/Mc Cable runs must be kept to a minimum length and it is not intended to be used in place of rigid/EMT conduit wiring methods.
12. EMT fittings shall be compression type – **NO SET SCREW FITTINGS!**
13. Crimp type “Quick Connect” style wire connectors shall not be used on any branch lighting or power circuits. Wire nuts shall be used for branch circuit terminations and splices.
14. All exterior disconnects, panels 100 AMPS and over, J-Boxes shall be rated NEMA 3 Gasketed or NEMA 4 Enclosures.
15. All flush-in-grade Quazite J-Boxes shall have traffic rated covers with tamper resistant cover assemblies.
16. Roof top conduit installation shall use Rigid, or IMC.
17. All empty underground conduits shall contain a tracer wire or magnetic tape for future location and line spotting efforts.
18. Design Enlarged Plans (1/4” scale) for Kitchens, Electrical Rooms, Mechanical Rooms, or other spaces where 1/8” scale is too small to show electrical design information.
19. No conduit runs underneath boilers
20. Coordinate with Architect for special architectural equipment requiring power and special wiring:
 - a. Design power for motorized doors at ADA doors.
 - b. At emergency egress doors, design power and controls for door power supplies and interlocks with the fire alarm systems and/or security alarm system.
 - c. Design power and control for electrically operated doors (garage door types).
21. Design power and controls for electrical hardware (electro-magnetic type) for entrance to secured areas controlled from an interior space.
22. Kitchens:
 - a. Identify electrical characteristics of all kitchen equipment on the Enlarged Kitchen Plans.

- b. Design a doorbell for kitchen receiving door. Doorbell switch height @ 5 ft. AFG Spec; doorbell switch to be heavy duty- Non-residential grade.
- c. Coordinate with kitchen consultant electrical characteristics, wiring connections, and branch circuiting wiring requirements.
- d. Design interlock wiring and controls with kitchen hood fire protection systems and HVAC exhaust equipment.
- e. Specify shunt-trip circuit breakers for all electric cooking equipment under the hood. Design "Hood Fire Protection Control Diagram" indicating shunt-trip control and interlock with hood fire protection system and gas solenoid valve.
- f. Design fire alarm inter-connections and wiring for the hood fire suppression system.

23. Elevators:

- a. Specify a fusible disconnect switch in the elevator equipment room for elevator motor and for 120V power.
- b. Dedicated GFCI duplex outlet and light fixture with switch in the elevator pit. **Light shall be on line side of GFCI receptacle.**
- c. Elevator sump pump shall be on dedicated Non-GFCI Circuit simplex receptacle.
- d. Specify smoke detector in all elevator lobbies on all floors and wiring to the elevator controller for "elevator re-call".
- e. Specify smoke detectors and heat detectors in the elevator shaft and elevator equipment room for "shunt-trip" functions. Specify shunt-trip circuit breaker in the elevator equipment room for shunting the elevator motor.
- f. Coordinate motor HP and electrical characteristics of the elevator with the Architect.
- g. Specify dedicated 120V branch circuit for the elevator cab lights with toggle switch and keyed lock located in the elevator equipment room, if not included in elevator package.
- h. Specify dedicated 120V branch circuit for the receptacles and elevator controls located in the elevator equipment room.
- i. Include Specification Section Elevator Electrical Requirements in the project manual.
- j. Design for 1" telephone conduit continuous from the elevator controller to the telephone backboard
- k. Specify that the Elevator Contractor shall provide training on elevator operation
- l. Specify and coordinate with the Architect that the elevator shall be provided with a vandal-resistant phone speaker box for dedicated "ring-down" provisions. A handset type phone will not be accepted.
- m. Research and comply with latest City of Albuquerque, county, state and national requirements for electrical and special system requirements.
- n. The ring down number to dial is (505) 243-7750

APPENDIX “ A” – ELECTRICAL IDENTIFICATION

- A. Identify Raceways of Certain Systems with Color Banding: Band exposed or accessible raceways of the following systems for identification. Bands shall be pre-tensioned, snap-around colored plastic sleeves, colored adhesive marking tape, or a combination of the two. Make each color band 2 inches wide, completely encircling conduit, and place adjacent bands of two-color markings in contact, side by side. Install bands at changes in direction, at penetrations of walls and floors and at 40-foot maximum intervals in straight runs. Apply the following colors:
- | | |
|--|-------------------|
| 1. Fire Alarm System: | Red |
| 2. Security Alarm Systems: | Blue and Yellow |
| 3. Mechanical and Electrical Supervisory System: | Green and Blue |
| 4. Data System: | Green and Yellow |
| 5. TV Systems: | Green |
| 6. Sound/PA: | Orange |
| 7. Telephone: | Orange and Yellow |
| 8. 120/208V Power: | Black |
| 9. 277/480V Power: | Blue |
| 10. 120/208V Emergency Power: | Black and Orange |
| 11. 277/480V Emergency Power: | Blue and Orange |
- B. Identify Junction, Pull, and Connection Boxes: Code-required caution sign for boxes shall be pressure-sensitive, self-adhesive label indicating system voltage in black, preprinted on orange background. Install on outside of box cover. Also label box covers with identity of contained circuits. Use pressure-sensitive plastic labels at exposed locations and similar labels.
- C. Use conductors with color factory-applied the entire length of the conductors except as follows under which conditions field applied color-coding methods may be used in lieu of factory-coded wire for sizes larger than No. 10 AWG:
1. Apply colored, pressure-sensitive plastic tape in half-lapped turns for a distance of 6 inches from terminal points and in boxes where splices or taps are made. Apply the last two laps of tape with no tension to prevent possible unwinding. Use 1 – inch – wide tape in colors as specified. Do not obliterate cable identification markings by taping. Tape locations may be adjusted slightly to prevent such obliteration.
- D. Tag or label conductors as follows:
1. Future Connections: Conductors indicated to be for future connection or connection under another contract with identification indicating source and circuit numbers.
 2. Multiple Circuits: Where multiple branch circuits or control wiring or communications/signal conductors are present in the same box or enclosure label each conductor or cable. Provide legend indicating source, voltage, circuit number, and phase for branch circuit wiring. Phase and voltage of branch circuit wiring may be indicated by mean of coded color of conductor insulation. For control and communications/signal wiring, use color coding or wire/cable marking tape at terminations and at intermediate locations where conductors appear in wiring boxes, troughs, and control cabinets. Use consistent letter/number conductor designations throughout on wire/cable marking tapes.
 3. Fiber Optic Cable and conduit: All fiber optic cable shall bear factory printed cable identification marking indicating the cable is “fiber optic”. Install permanent ink markings indicating the words “fiber optic” on colored tape or tags to this effect on conduit runs containing fiber optic cable at changes in direction, at penetrations of walls and floors (each side), at junction boxes and termination, and at 40 foot maximum intervals

APPENDIX "B" – STANDARD DRAWINGS

