

JANUARY 2024



**ALBUQUERQUE
PUBLIC SCHOOLS**

ROOF DESIGN GUIDELINES & SPECIFICATIONS

FACILITIES DESIGN + CONSTRUCTION / MAINTENANCE & OPERATIONS

CONTENTS

GENERAL ROOF DESIGN GUIDELINES	1
GENERAL DESIGN GUIDELINES FOR ROOF MOUNTED PHOTOVOLTAIC (PV) SYSTEMS.....	4
SECTION 06 10 00 – ROUGH CARPENTRY	5
PART 1 – GENERAL	5
1.1 RELATED DOCUMENTS	5
PART 2 – PRODUCTS	5
2.1 NAILERS	5
2.2 PLYWOOD.....	5
2.3 CARBON STEEL FASTENERS	5
PART 3 – EXECUTION	7
3.1 NAILERS	7
3.2 PLYWOOD.....	8
SECTION 07 51 10 – BUILT-UP ASPHALT ROOFING OVER INSULATION	9
PART 1- GENERAL.....	9
1.1 RELATED DOCUMENTS	9
1.2 SCOPE OF WORK.....	9
1.3 BIDDER’S REPRESENTATION	9
1.4 QUALIFICATIONS	10
1.5 SUBMITTALS	10
1.6 INSPECTIONS	11
1.7 WARRANTY	12
1.8 ENVIRONMENTAL REQUIREMENTS	12
PART 2 – PRODUCTS	13
2.1 MANUFACTURER.....	13
2.2 ROOF INSULATION PRODUCTS	13
2.3 ROOF SYSTEM.....	13
PART 3 – EXECUTION	15
3.1 INSPECTION	15
3.2 INSTALLATION	16
3.3 WOOD NAILER LOCATION AND INSTALLATION	16



3.4	INSULATION INSTALLATION.....	17
3.5	MEMBRANE INSTALLATION.....	18
3.6	PROTECTION.....	20
3.7	TEMPORARY CLOSURE.....	20
3.8	CLEANUP	20
SECTION 07 51 30 – BUILT-UP ASPHALT ROOFING OVER LWIC		22
PART 1 – GENERAL.....		22
1.1	RELATED DOCUMENTS	22
1.2	SCOPE OF WORK.....	22
1.3	BIDDER’S REPRESENTATION	22
1.4	QUALIFICATIONS	23
1.5	SUBMITTALS	23
1.6	INSPECTIONS	23
1.7	WARRANTY.....	25
1.8	ENVIRONMENTAL REQUIREMENTS	25
PART 2 – PRODUCTS		25
2.1	MANUFACTURER.....	25
2.2	ROOF INSULATION PRODUCTS	25
2.3	TEMPORARY ROOF	26
2.4	ROOF SYSTEM.....	27
PART 3 – EXECUTION		29
3.1	INSPECTION	29
3.2	INSTALLATION	30
3.3	WOOD NAILER LOCATION AND INSTALLATION	30
3.4	INSULATION INSTALLATION (SUBSTRATE FOR THE TEMPORARY ROOF).....	31
3.5	TEMPORARY ROOF INSTALLATION	31
3.6	MEMBRANE AND FLASHING INSTALLATION.....	32
3.7	PROTECTION.....	35
3.8	TEMPORARY CLOSURE.....	35
3.9	CLEANUP	35
Exhibit A – FRTW Nailer Attachment Guidelines (Info Only)		36

GENERAL ROOF DESIGN GUIDELINES

This section of the document was developed as a guide for basis of design and is not intended to be directly included in the Project Manual

1. Design to meet current International Building Code standards edition applicable to project.
2. Current APS/PSFA Specifications:
 - a. Built Up Roofing over Insulation (January 2017)
 - b. Built Up Roofing over Light Weight Insulating Concrete (LWIC) (January 2017)
3. Include the following language in the Division 5 Sheet Metal Decking (05 30 00) for puddle welds:
 - a. Preferred method of attachment is tek screw or powder actuated i.e. Hilti
 - b. Galvanizing Repairs: Prepare and repair damaged galvanized coatings on both surfaces of deck with galvanized repair paint according to ASTM A780 and manufacturer's written instructions.
 - c. Repair Painting: Wire brush and clean rust spots, welds, and abraded areas on both surfaces of prime-painted deck immediately after installation and apply repair paint.
 - d. Provide final protection and maintain conditions to ensure that the steel deck is without damage or deterioration at the time of Substantial Completion.
4. Make sure the Division 6 Rough Carpentry Section (06 10 00) does not indicate any Pressure Treated wood on the roof area. All wood blocking, nailers, parapet framing coverings, etc. are to be Fire-Retardant Treated Wood only. **See ES-1 Nailing Schedule (Guid06 10 00 located in this document and Exhibit A).**
5. **Sheet Metal Flashing and Trim:** All coping and edge metal securement must meet ES-1 standard. Continuous cleats and tapered perlite shall be used under the coping cap. **No chair systems are allowed.**
6. **Acceptable Roof Top Equipment:** Only Energy Recovery Ventilator (ERV) units, exhaust fans and hoods, and mini-split condensing units will be allowed. If other roof top units are proposed, written approval from FD+C Roofing construction managers, FD+C HVAC project manager, and M&) HVAC director is required.

7. **Roof Top Accessories:** Roof top ladders/parapet wall crossing ladders cannot touch the roof membrane and must have a walk pad placed at the landings. If crossing a parapet, provide a minimum 6" clearance above the coping cap/top of parapet wall. Provide a walk-plate surface across the coping cap/parapet.
8. All roof top penetrations, including the roof hatch, must be a minimum of 8" above the finished roof system.
9. All mechanical equipment curbing must allow for 18" radius clearance above the finished roof system. This can be accomplished with a curb only or a combination of curb and metal equipment stand/rack.
10. When using bituminous flashing products (i.e. JM PermaFlash product for penetrations or GAF approved equal), A/E must specify one coat of TopGard Base Coat and two coats of TopGard 4000 be applied. A minimum of ninety days must elapse prior to the applications of the coating. No aluminizing is acceptable.
11. All penetrations will have a minimum of 18" radius clear space to allow for warrantable flashing.
12. Crickets are to be dimensioned on the drawings. Calculation: $(1/6 \text{ the distance between roof drains plus the distance the roof drain is from the wall}) \div 4$. Always round up to 4' intervals for maximum material usage.
13. Canales/Scuppers: All canales and/or scuppers must have a metal pan lining extending not less than 6 inches (152mm) past the inside of the parapet and not less than 6 inches (152mm) from each side of the canale or scupper opening. All canales and scuppers must have positive drainage.
14. If this is a LEED project, A/E must ensure either JM GlasKap CR G or GAF EnergyCap cap sheet material is specified.
15. Roof drains shall be Froet drains. Use the LP "Low Profile" OFS "Overflow Strainer" detail. Ensure the details identify the appropriate extension ring detail (DEX) and elevation from the roof deck. Separated main/overflow drain units will be allowed.
16. Any roofing slope over 1"/12" needs to have back-nailing identified on the construction drawings for the GC to install.
17. An isometric drawing of the roofing system will be detailed in the drawings for every roofing system called for in the specifications.
18. All material transitions need to be thoroughly detailed (i.e. coping terminations, roof membrane transitions, etc.)
19. Provide walkway pads around all HVAC units, condensing units, roof hatch landings, and ladder landings.

20. Specify a 4-sided roof hatch safety railing that is to be mounted to the roof hatch (see products by KeeHatch®, Bilco®, SafePro®, etc. for examples). Safety railing is to be made of aluminum; fiberglass or PVC frames will not be allowed. Ladder-mounted extension safety bars will not be allowed.
21. Specify that slip sheets be installed underneath all pipe support stands or duct support stands (where applicable). Contract documents should indicate how the material will be supplied and installed.
22. A/E to utilize structural slope wherever possible.
23. Where applicable, A/E to specify face-mounted security cameras in lieu of the “arm bracket” mount that is fastened through the parapet roof membrane.
24. No Portals Plus flashing systems or pitch pans will be allowed.

END SECTION

GENERAL DESIGN GUIDELINES FOR ROOF MOUNTED PHOTOVOLTAIC (PV) SYSTEMS

This section of the document was developed as a guide for basis of design and is not intended to be directly included in the Project Manual

1. Consult the roofing manufacturer's technical representative for specific requirements related to roof mounted PV systems.
2. Roof-mounted PV systems must not compromise the manufacturer's 20-year NDL warranty.
3. Coordinate all equipment and penetration locations with PV array location(s) to eliminate conflicts.
4. Coordinate PV array location(s) with crickets/flow lines to eliminate disruptions in the positive drainage of the roof system.
5. Only ballasted racking systems may be utilized.
6. For all ballasted racking systems, where the stands sit on the finished roof membrane, provide an additional membrane layer or slip sheet to prevent damage. Consult the roofing manufacturer's technical representative for product and installation requirements.
7. Provide walk pads at high-traffic areas around the PV array. Consult the roofing manufacturer's technical representative for product and installation requirements.
8. Prior to the installation of the photovoltaic system, an inspection of the finished roof system shall be conducted by the roofing manufacturer's representative, design professional, general contractor, and APS roofing construction manager. Installation of the PV system may not begin until written approval is granted from the manufacturer's representative. If any items require correction at the time of PV pre-installation inspection, it will be the responsibility of the Contractor to correct any items before installation of the PV system may continue. Corrective measures shall be determined by the manufacturer's representative in order to maintain the warranty.
9. For additional information and requirements, consult the "Solar Photovoltaic System Design Guidelines" document found on the APS Facilities Design + Construction website.

END SECTION

SECTION 06 10 00 – ROUGH CARPENTRY

PART 1 – GENERAL

1.1 RELATED DOCUMENTS

- A. Drawings and general provisions of the Contract, including General and Supplementary Conditions and Division 1 Specification Sections, apply to this Section.

1.2 SUMMARY

- A. Types of work in this section include rough carpentry requirements for nailers, plywood, and carbon steel fasteners to be included with the overall roof system.

PART 2 – PRODUCTS

2.1 NAILERS

- A. All nailers shall be #2 or better, construction grade lumber, FRTW.
- B. Nailer size shall be indicated on the drawings.
- C. Minimum nailer size shall be 2"x6" (nominal).
- D. Minimum nailer thickness shall be 1 ½" (nominal).
- E. Nailers shall extend ½" beyond metal flanges.

2.2 PLYWOOD

- A. All plywood is to be minimum ½", APA Rated Exterior, Structural 1, and FRTW. Only waterproof glue is acceptable.
- B. Refer to drawings for plywood thickness at each detail.

2.3 CARBON STEEL FASTENERS

- A. All fasteners must be carbon steel with corrosion-resistant coating. Fasteners shall meet FM 4470.
- B. Masonry/Concrete Fasteners:
 - 1. Corrosion-resistant, threaded fastener with low-profile head.
 - 2. Fasteners shall be a minimum of 3/16" diameter with a 1" minimum embedment.

3. Fastener to be FM Global approved.
 4. Approved Products:
 - a. Tapcon Flat-Head Phillips with Blue Climaseal or White UltraShield by ITW Buildex.
 - b. Tapper Flat-Head Phillips with Perma-Seal Coating by Powers Fasteners, Inc.
- C. Steel/Wood Fasteners
1. Corrosion-resistant, self-tapping, self-drilling screw with low-profile head.
 2. Fastener to be FM Global approved.
 3. Approved Products:
 - a. Roof Grip by OMG with Climaseal Coating.
 - b. Dekfast by SFS Intec, Inc., with Senti Coating.
 - c. Standard roofing fastener by OMG, with CR-10 coating.
 4. Fasteners to be #12 minimum and of sufficient length to penetrate into steel $\frac{3}{4}$ inch and wood 1 inch.
- D. Gypsum/Cementitious Wood Fiber Decking
1. Corrosion-resistant, $\frac{1}{4}$ " toggle bolt with low-profile head. Fastener to be carbon steel with fluorocarbon, corrosion-resistant coating.
 2. Fastener shall be FM Global approved.
 3. Approved Products:
 - a. Speed-Lock Toggle by Powers Fasteners, Inc.
 - b. Iron-Lock Toggle bolt by OMG.
 4. Fastener shall be of sufficient length to penetrate deck as required for proper application, in accordance with the manufacturer's recommendations.
- E. Washers
1. Round, carbon steel, Federal Specification FF-2-92. Minimum diameter $\frac{5}{8}$ ".

PART 3 – EXECUTION

3.1 NAILERS

- A. Nailers are to be installed as per detailed drawings.
- B. Discard units of material with defects that might impair quality of work and units that are too small to use in fabricating work with minimum joints or optimum joint arrangement.
- C. Set nailers to required levels and lines with members plumb and true.
- D. All perimeter nailers shall be of uniform height within a given roof section.
- E. Nailers shall be installed and $\frac{1}{4}$ " gap between ends of adjoining pieces.
- F. Stacked nailers shall have the joints staggered a minimum of 24"
- G. Nailers shall be fastened in accordance with the following schedule:
 - 1. Fasteners in 6" or wider (nominal) lumber shall be installed in two (2) rows, staggered on-third of nailer width. Listed spacings indicate distance between fasteners in adjacent rows.
 - 2. Two (2) fasteners shall be installed within 6" of each nailer end.
 - 3. Corner fastener spacing shall extend 8' from all outside building corners.
 - 4. Where two or more nailers are installed, each nailer shall be fastened independently.
 - 5. Over all deck types, the bottom nailer shall be fastened using the specified fasteners and 5/8" diameter washers. Countersink washers and fasteners level with top of wood using spade bit or similar method. Fasten subsequent nailers, where specified, using the specified screws without washers.
 - 6. Nailer Attachment Schedule: The following nailer attachment schedule is to be included in the project specifications manual. Nailer isometric detail is to be included in the construction drawings:

Attachment Substrate	Perimeter Fastener Spacing (max)	Corner Fastener Spacing (max)
Structural Concrete	12" o.c.	6" o.c.
CMU (fastener into solid material)	12" o.c.	6" o.c.
Steel Deck	12" o.c.	6" o.c.
Wood	12" o.c.	6" o.c.

3.2 PLYWOOD

- A. Plywood is to be installed as per detail drawings.
- B. Plywood joints must be true and well fitting, allowing for expansion and contraction. Allow 1/8" at end and edge joints.
- C. Plywood fasteners shall be installed in a uniform grid pattern, with a maximum spacing of 18" o.c. between adjacent fasteners.

END SECTION

SECTION 07 51 10 – BUILT-UP ASPHALT ROOFING OVER INSULATION

PART 1- GENERAL

1.1 RELATED DOCUMENTS

- A. Drawings and general provisions of the Contract, including General and Supplementary Conditions, general project requirements and Division 1 Specifications Sections, apply to this Section.

1.2 SCOPE OF WORK

- A. Provide a complete roof system of insulation, hot mopped felts, cap sheet, flashings, sealants, and accessories.

1.3 BIDDER'S REPRESENTATION

- A. A large part of the value of this work is contained in the bidder's and the bidder's proposed manufacturer's capacity to provide long-term responsibility for the satisfactory performance of the roof. A 20-year, no dollar limit warranty is required. To that end, the following requirements are essential provisions of this specification:
 - 1. By offering a bid for this work, the bidder certifies that he has visited the site and determined that all the conditions of the surrounding and underlying work are consistent with his proposed manufacturer's requirements for the specified warranty. In the event that the bidder discovers any condition of the surrounding and underlying work that would prevent him or his manufacturer from providing the specified warranty, he shall report it to the design professional not less than ten (10) days before the bid opening.
 - 2. By offering a bid for this work, the bidder certifies that he has examined the Contract Documents and has found all the details and requirements of the scope of work are complete and consistent with his proposed manufacturer's requirements for the specified warranty. In the event that the bidder discovers any detail or requirement in the Contract Documents that would prevent him or his manufacturer from providing the specified warranty, he shall report it to the design professional not less than ten (10) days before the bid opening.
 - 3. By offering a bid for this work, the bidder certifies that he can, within ten (10) calendar days of a notice of award from the Owner, provide a surety bond for the performance of the work, a surety bond for payment of labor and materials, and a specimen warranty certificate from the manufacturer whose system he proposes to use on the project.

1.4 QUALIFICATIONS

A. Manufacturer Qualifications

1. The manufacturer of the roof system shall be the actual manufacturer of the roofing and insulation component materials, and shall have not less than fifteen (15) years of experience in the production of the specified system.
2. The contractor shall include a certification from the manufacturer, on the manufacturer's letterhead, that the proposed membrane and insulation materials will be produced by the manufacturer of record.

B. Installer Qualifications

1. The installer of the built-up roofing shall have been engaged in the business of installing built-up roofing for not less than five (5) years and shall be experienced in the layout and application of this material. The crew shall be composed of experienced and skilled workers in this work.

1.5 SUBMITTALS

- A. Shop Drawings: Submit in accordance with Conditions of Contract and Division 1 Specification Sections, indicating roof size, membrane attachment layout, location, and type of penetrations, perimeter and penetration details, roof insulation make-up and layout.
- B. Product Data Submittals: Include manufacturer's technical product data, including UL product listing for each type of insulation, deck, fasteners and roofing product required.
- C. Fire Resistance: Provide roofing system, insulation, and component materials that have been tested for application and slopes indicated and are listed by Underwriters Laboratories, Inc. (UL) for Class A external fire exposure over decks specified herein.
- D. Wind Uplift: Provide rigid insulation, mechanically fastened roofing system, and component materials suitable for the structural deck and that have been tested as a complete system for application and slopes indicated. Provide a complete outfit of submittals ready for review. Allow sufficient time for review of the submittal. Provide fastening for uplift resistance to meet the applicable Building Code but in no case less than ninety (90) psf.

1.6 INSPECTIONS

- A. During the roofing system installation, the Contractor shall take five (5) digital photos daily of the work in progress. The photos shall be forwarded to the Design Professional and the Owner's Representative on a daily basis with a brief caption of the roofing area being installed and the products being used.
- B. After the roofing system installation is complete, the manufacturer shall inspect the work and inform (by written report) the design professional, contractor, and the installer of defective/incomplete work to be remodeled. Those areas indicated shall be corrected to the full satisfaction of the design professional, Owner, and manufacturer. The manufacturer shall submit written acceptance of the project to the design professional to issuance of the weather-tightness warranty.
- C. Inspections shall be performed at each transition of roof detail encountered for each phase of roofing for the duration of the project. An experienced, full-time employee of the manufacturer, with experience in similar inspections over the past two years, must conduct each inspection.
- D. As part of the District's initiative to ensure field quality control, a **Simulated Rain Test** shall be conducted as follows:
 - 1. After completion of the four ply-membrane installation and prior to the installation of the cap sheet membrane, a water test shall be coordinated and conducted by the Contractor in the presence of the Design Professional and the Owner's representative. The Contractor shall give the Design Professional and the Owner's representative a minimum of 48 hours' notice prior to conducting the water test. The Design Professional shall be responsible for documenting the water test results.
 - 2. Prior to the water test, the Contractor shall ensure that the roof area(s) to be tested have been cleaned of debris and all roof drains are sufficiently plugged.
 - 3. The Contractor shall provide and/or arrange for all necessary equipment, supplies, water, etc. as needed to perform these tests. This may include a water truck with a fire hose, if necessary.
 - 4. At the direction of the Owner's Representative, apply simulated rain over all roof areas for at least 15 minutes per area, or as otherwise directed.
 - 5. In addition to the simulated rain test, direct water at all walls, windows, units, penetrations, etc. that occur adjacent to, or within each roof area, using a continuous, unforced hose stream.
 - 6. Plug all roof drains and scuppers in each drainage area and allow each drain/scupper sump to be filled to a depth of 3-4 inches. Allow water to stand for a minimum of 2 hours. The Contractor shall maintain photo documentation of the sump locations that the water level has maintained a constant level for the time period required. These photos shall be provided to the Owner's Representative upon request.

7. Upon completion of the water test but before the end of each day, unplug drains/scuppers and ensure the water flows freely without restriction. There will be no overnight testing.
8. Perform any necessary corrections to defects noted (including the insuring of positive drainage around all curbs, roof openings, and crickets to roof drains or scuppers) during or after the water test. Additional testing shall be performed as necessary to further define sources of any noted leakage. All defects and/or corrections shall be made prior to the installation of the cap sheet membrane and the Owner's representative shall be informed when the corrections are complete.

1.7 WARRANTY

- A. **Manufacturer's Warranty:** Provide roofing manufacturer's total system leak-tight 20-year "No Dollar Limit Warranty," including insulation. Provide all details necessary to qualify for manufacturer's 20-year "No Dollar Limit Warranty."
- B. **Rofer's Guarantee:** Provide written guarantee from the Contractor stating that the Contractor will respond within twenty-four (24) hours and repair within five (5) business days, any leaks or defects in the roofing assembly for two (2) years at no cost to the Owner.

1.8 ENVIRONMENTAL REQUIREMENTS

- A. Install roofing materials only when surfaces are clean, dry, smooth, and free of snow or ice.
- B. Do not apply roofing membrane during inclement weather or when ambient conditions will not allow proper application. Consult manufacturer's technical specifications on cold weather application.
- C. If during the course of the project, the rooftop mechanical equipment (heating and/or cooling) must be taken out of service to accomplish the work, the General Contractor shall provide temporary portable heating and/or cooling systems to maintain the building's interior environment equal to the building's own heating and/or cooling system.

PART 2 – PRODUCTS

2.1 MANUFACTURER

- A. Provide a four-ply felt with a one-ply mineral surfaced fiberglass cap sheet built-up roofing system. This is a minimum performance specification. Other manufacturer's systems may qualify, as determined by the design professional.

2.2 ROOF INSULATION PRODUCTS

- A. Perlite Board Roof Insulation: Rigid, noncombustible, perlite/fiber boards of thickness indicated and complying with ASTM C-728; manufacturer's standard sizes.
- B. Wood Fiber Roof Insulation: High density wood fiber board tested in accordance with ASTM C208 where permitted by code and system requirements.
- C. Polyisocyanurate Foam Roof Insulation: Insulation shall be a close cell, polyisocyanurate foam core with factory-laminated facers conforming to ASTM specification C 1289-01, Type II, Class 1. Foam core shall have a rated flame spread of 25 or less according to ASTM E 84. Insulation shall have minimum compressive strength of 20 psi (Grade 2) according to ASTM C 1289-01. Insulation shall be supplied in 4'x4' boards for adhered applications and 4'x8' boards for mechanically attached applications.
- D. Perlite cant strip complying with ASTM C-728.
- E. Tapered edge strips, non-flammable perlite taper strips complying with ASTM C 209.
- F. Mechanical Fasteners: Provide fasteners and plates listed in the approved report as part of the total assembly proposed. Fasteners shall be installed in patterns as required for the specified rigid insulation by the manufacturer to produce the required wind uplift resistance.

2.3 ROOF SYSTEM

- A. Approved Manufacturers
 - 1. Johns Manville Roofing Systems Group, Specification 5GIC
 - 2. GAF Material Corporation, Specification I-O-5-M-/P6
- B. Roofing Felts
 - 1. Ply Sheets: Four plies of asphalt-impregnated glass fiber mat complying with ASTM D2178, Type VI.
 - 2. Felt Envelopes: Non-perforated, asphalt-saturated organic roof felt complying with ASTM D 226, Type I.

3. Mineral surfaced fiberglass cap sheet complying with ASTM D 3909.
 - a. GlasKap by Johns Manville (GlasKap CR G for LEED projects).
 - b. GAF Glas Mineral Cap Sheet by GAF (EnergyCap for LEED projects).
- C. Roofing Bitumen
 1. Low fuming/low odor asphalt bitumen complying with ASTM D 312. Asphalt shall be domestically manufactured in the United States and as approved by the roofing system manufacturer.
 - a. Approved Products
 - i. Trulo Max by Owens Corning Trumbull
 - ii. No Smell Asphalt by Continental Materials
 - iii. No Smell Asphalt by United Asphalt
 - iv. Hot Stuff Asphalt's "Lite Packs"
 - b. Interply Moppings- Type III, IV
 - c. Glaze Coat- Type III
 - d. Flashings- Type III or IV, as recommend by manufacturer
 2. Contractor shall provide and maintain a fume recovery system acceptable to the Owner for the duration of the project to control fumes/odors associated with bitumen kettles.
- D. Flashings
 1. Base Flashing Materials: Two plies of material base ply shall be SBS polymer modified bitumen reinforced with a polyester and/or glass fiber mat. (Top ply shall be the highly reflective fiberglass reinforced mineral cap sheet if LEED project).
 - a. Dynalastic 180S and Glaskap by Johns Manville Roofing Systems Group
 - b. Rubberoid Mop Smooth and GAF Glas Mineral Cap by GAF Material Corp.
 2. Strip Flashing Materials: One ply of granule-surfaced SBS polymer modified bitumen sheet reinforced with a polyester and/or glass fiber mat:
 - a. Dynalastic 180S by Johns Manville Roofing Systems Group.
 - b. Ruberoid Mop Smooth by GAF Material Corporation.

- E. Walkways
 - 1. Granule-surfaced modified asphalt boards:
 - a. DynaTred by Johns Manville Roofing Systems Group
 - b. 2-layer SBS mopped together. Consult GAF Material Corporation
- F. Asphalt Roof Cement
 - 1. To comply with ASTM D 4586, asphalt roof cement (asbestos free) or roofing membrane manufacturer supplied SBS modified asphalt roof cement (asbestos free), as required.
- G. Related Materials
 - 1. Lead flashing for roof drains shall be 27"x27" and be a minimum four (4) pound lead.
 - 2. Pipe or vent jackets shall be a minimum three (3) pound lead with cap designed for use on flat roof construction.
 - 3. Perma-Flash is an acceptable alternative to lead pipe jackets. Perma-Flash system requires 1 coat of TopGuard Base Coat and 2 coats of TopGuard 4000 to final product.
 - 4. MajorSeal Liquid Flashing by GAF Material Corporation.
 - 5. Wood nailers: Shall be FRTW only on any roofing surfaces.
 - 6. Flashing securement devices shall be of adequate design to achieve substantial completion and positive drainage.
 - a. Anchor bars for flashing securement to concrete or masonry substrates shall be 1/8" x 1" flat aluminum bar with 8" hole spacing by OMG, or approved equal.

PART 3 – EXECUTION

3.1 INSPECTION

- A. The Contractor shall be responsible for suitable substrate to accept the roofing system.
- B. Installer of roofing system shall examine substrate and conditions under which roofing work is to be performed and shall notify the Architect and Owner representative immediately of unsatisfactory conditions. Do not proceed with roofing work until unsatisfactory conditions have been corrected in manner acceptable to installer and manufacturer.

- C. Before roofing work may begin, the design professional shall conduct a pre-roofing coordination meeting. It shall be attended by the Owner's representative, PSFA representative (as required), the General Contractor, the roofing contractor, the roofing manufacturer's rep, (local sales rep is acceptable), and all other subcontractors who have any components of their work on or penetrating the roof. The participants shall:
- D. As much as possible by visual inspection and by the cutting of core samples, verify that surfaces and site conditions are ready to receive work.
 - 1. Examine roof deck to determine that it is sufficiently rigid to support roofers and their mechanical equipment and that deflection will not strain or rupture roof components or deform deck.
 - 2. Verify roof deck is clean and smooth, free of depressions, waves, or projections, properly sloped to insure drainage. Examine substrate to determine that surface is in a suitable condition for roofing work.
 - 3. Verify roof openings, curbs, pipes, sleeves, ducts, and vents through roof are solidly set, and cant strips, wood nailing strips, and reglets are in place. Verify that all curbs and penetrations have been laid out and installed with adequate vertical and horizontal clearance as required by the manufacturer to provide the specified warranty.
 - 4. The condition of the surface to receive roof insulation shall be firm, clean, smooth, and dry. Do not start roof application until defects have been corrected.

3.2 INSTALLATION

- A. General: Comply with manufacturer's written instruction for installation of the roof system.
- B. All flashings shall be installed concurrently with the roofing membrane as the job progresses. No temporary flashings shall be allowed without the prior written approval of the Owner's Representative. If any water is allowed to enter under the newly completed or existing roofing due to incomplete flashings, seams and or night seals, the affected area shall be removed and replaced at the Applicator's expense.
- C. Phased Construction & Completion Requirements:
 - 1. Phased construction will not be permitted on this project. However, if, due to a foreseeable weather event, phased construction is required, the Contractor shall request (in writing) the approval of phased construction from the Design Professional, roofing manufacturer, and the Owner's Representative.

3.3 WOOD NAILER LOCATION AND INSTALLATION

- A. Nailers are to be installed as per detail drawings.

- B. Discard units of material with defects that might impair quality of work and units that are too small to use in fabricating work with minimum joints or optimum joint arrangement.
- C. Set nailers to required levels and lines with members plumb and true.
- D. All perimeter nailers shall be of uniform height within a given roof section.
- E. Nailers shall be installed with ¼" gap between ends of adjoining pieces.
- F. Nailers shall be fastened in accordance with the following schedule:
 - 1. Fasteners in 6" or wider (nominal) lumber shall be installed in two (2) rows, staggered one-third of nailer width. Listed spacings indicate distance between fasteners in adjacent rows.
 - 2. Two (2) fasteners shall be installed within 6" of each nailer end.
 - 3. Corner fastener spacing shall extend 8' from all outside building corners.
 - 4. Where two or more nailers are installed, each nailer shall be fastened independently.
 - 5. Over all deck types, the bottom nailer shall be fastened using the specified fasteners and 5/8" washers. Countersink washers and fasteners level with top of wood using spade bit or similar method. Fasten subsequent nailers, where specified, using the specified screws without washers.
 - 6. When nailers are stacked, stagger the layer ends no less than 24".
 - 7. Unless noted otherwise on the drawings, nailers should be installed as detailed in the Nailer Attachment Schedule 06 10 00, 3.1 Nailers).

3.4 INSULATION INSTALLATION

- A. Installing Insulation: Install only as much insulation as can be covered with the roofing membrane and completed before the end of the day's work or before the onset of inclement weather.
- B. Fit Insulation: Neatly fit insulation to all penetrations, projections, and nailers. Insulation should be loosely fitted, with gaps greater than one quarter inch (1/4") being filled with acceptable insulation. Under no circumstances should the membrane be left unsupported over a space greater than one quarter inch (1/4"). Tapered or feathered insulation should be installed around roof drains so as to provide proper slope for drainage.
- C. Two-Layer Installation: Where overall insulation thickness is two (2) inches or greater, install required thickness in two layers with joints of second layer staggered from joints of the first layer a minimum of twelve (12) inches each direction.

- D. **Attach Insulation:** Insulation must be attached using Fasteners and Insulation Plates. Refer to the Technical Information for attachment patterns and rates for specific insulation types and thickness. In a multi-layer insulation assembly, the type and thickness of the top layer of insulation determine fastening pattern. Insulation fasteners shall penetrate the top of the flutes and shall not extend into the building interior. Roofing contractor is liable for replacing fasteners that extend beyond the bottom of the flutes.
- E. **Stagger Insulation Joints:** When installing multiple layers of insulation, all joints between layers should be staggered.

3.5 MEMBRANE INSTALLATION

- A. **Asphalt Bitumen Heating:** Heat and apply bitumen in accordance with equiviscous temperature method ("EVT Method") as recommended by NRCA. Do not raise temperature above minimum normal fluid-holding temperature necessary to attain EVT (plus 25°F at point of application) more than one hour prior to time of application. Discard bitumen that has been held at temperature, exceeding finished blowing temperature (FBT) for a period exceeding 3 hours.
- B. Contractor shall provide and maintain a fume recovery system acceptable to the Owner for the duration of the project to control fumes/odors associated with bitumen kettles.
- C. **Quality Control:** Contractor's asphalt kettle shall be equipped with an accurate built-in thermometer. Contractor shall also have available at the site and additional portable thermometer for checking temperature of asphalt at the point of application and for use as a check on the kettle thermometer.
- D. **Bitumen Mopping Weights:** For interplay mopping, and for other mappings except as otherwise indicated, apply bitumen at the rate of 25 pounds of asphalt (plus or minus 25 percent on a total-job average basis) per roof square (100 sq. ft.) between plies.
- E. **Substrate Joint Penetrations:** Do not allow bitumen to penetrate substrate joints and enter building or damage insulation, vapor retarders, or other construction. Where mopping is applied directly to a substrate, tape joints or, in the case of steep asphalt, hold mopping back 2 inches from both sides of each joint.
- F. **Cutoffs:** At end of each day's roofing installation, protect exposed edge of incomplete work, including ply sheets and insulation. Provide temporary covering of 2 plies of No. 15 roofing felt set in full moppings of hot bitumen; remove at beginning of next day's work. Glaze-coat areas of completed organic ply sheets before end of each day's work.

- G. Roofing Membrane Installation: Apply a piece 9" wide, then over that, one 18" wide, then over that, one 27" wide. Over these 3 partial sheets install a full width 36" piece. The following felts are to be applied full width, overlapping the preceding felts by 27-1/2" so that at least 4 plies of felt cover the substrate at all locations. Install each felt so that it is firmly and uniformly set, without voids, into the hot bitumen (within $\pm 25^{\circ}\text{F}$ of the EVT) applied just before the felt at a nominal rate of 23 lbs. per square, over the entire surface. Installation over porous substrates such as roof insulation may require up to 33 lbs. of hot bitumen per square.
- H. Surfacing: Prior to application of the fiberglass reinforced mineral surfaced cap sheet, cut the cap sheet into handleable lengths (12' - 18'). Lay the material out on the roof and allow it to relax and flatten. To accommodate a full width sheet, apply a mopping of hot asphalt, approximately 20°F above the EVT, at a nominal rate of 25 lbs. per square. (The higher temperature of asphalt maximizes the bonding of the cap sheet to the ply felts.) Then flop the cap sheet into the hot asphalt. On subsequent courses, the cap sheet is positioned upside down, directly over the sheet in the preceding course such that the side lap area of the preceding sheet is exposed. Care should be taken to maintain 2" side laps and 6" end laps.
- Asphalt is applied in the same manner as before, making sure to also cover the 2" exposed side lap. Asphalt may also be applied to the exposed "upside down" cap sheet, prior to "flopping" it into the hot asphalt. The cap sheet must be firmly and uniformly set, without voids, into the hot asphalt with all edges and laps well sealed.
- I. Care shall be taken not to track bitumen onto the finished exposed membrane. Full adhesion shall be achieved and all edges shall be well sealed. Leading and trailing edges of T-laps in both plies shall be hand rolled to prevent formation of voids. Asphalt shall bleed out one quarter inch (1/4") to one half inch (1/2") at laps. #11 color match granules shall be broadcast into asphalt bleed out while hot so that the finished appearance is uniform and neat.
- J. Set-On Accessories: Where small roof accessories are set on built-up roofing membrane, set metal flanges in a bed of roofing cement and seal penetration of membrane with bead of roofing cement to prevent flow of bitumen from membrane.
- K. Composition Flashing and Stripping: Install composition flashing at cant strips and other sloping and vertical surfaces, at roof edges and at penetrations through roof.
- L. Application of Base Flashing: The roofing membrane must extend to the top of the cant. The completed base flashing shall extend not less than 8" or more than 24" above the level of the roof, and shall extend onto the roof membrane a minimum of 4".
1. Starting just below the point on the parapet where the base flashing will terminate, mop the parapet and the surface on the roofing felts on the cant with hot Type III or Type IV asphalt. Immediately place the backer felt into the hot bitumen, smoothing the felt to set it firmly into the bitumen. The bottom edge of the backer felt should terminate at the bottom edge (base) of the cant. Do not extend the backer felt onto the horizontal membrane surface. Laps in the backer felt should be a minimum of 2".

2. All flashings shall be installed in 39" long pieces, cut from the end of the roll. Starting just above the top edge of the backer felt, mop the wall, the surface of the backer felt and out onto the roof membrane with hot Type III or IV asphalt. Holding the upper corners of the flashing, position "its lower horizontal edge on the roof membrane (minimum 4" from base of the cant) and lay it into place over the cant strip and up the wall. The sheet should be "worked-in" to ensure that it is firmly and uniformly bonded. In cool or cold weather, the back of the flashing sheet should also be mopped with the hot bitumen, and shorter lengths of flashing should be used. Laps in the flashing should be minimum of 3" and be well sealed.
 3. Mechanically fasten the base flashing on 6" centers along its top edge. Fasteners must have a 1" minimum diameter integral cap, or be driven through 1" minimum diameter rigid metal discs.
 4. All inside and outside corners and vertical laps shall be three-coursed with asphalt roof cement and reinforcing fabric, with #11 color matched granules broadcast and pressed into the cement while wet.
- M. Roof Drains: Fill clamping ring base with a heavy coating of roofing cement. Extend built-up roofing membrane into clamping ring or, where not feasible, provide two-ply of glass-fiber-reinforced flashing mopped with Type III asphalt and extended into clamping ring. Extend flashings onto built-up asphalt roofing system 6 inches and 10 inches, respectively. Before pacing clamping ring, set 2 plies of glass-fiber fabric in roofing cement and coat with roofing cement. Extend each fabric into clamping ring and for distances of 14 inches and 16 inches, respectively, onto built-up roofing.
- N. Installation of Roof Accessories: Miscellaneous sheet metal accessory items, including insulation vents and other devices, and major items of roof accessories (if any) to be coordinated with built-up roofing system work, are specified in other sections of these specifications.

3.6 PROTECTION

- A. Protect building surfaces against damage from roofing work. Where traffic must continue over finished roof membrane, protect surfaces.

3.7 TEMPORARY CLOSURE

- A. Temporary closures to ensure that moisture does not damage any completed section the new roofing system are the responsibility of the roofing contractor. Completion of flashing, terminations, and temporary closures should be complete as required to provide a watertight condition. Any material contaminated by a temporary closure must be cut out and discarded prior to resumption of installation.

3.8 CLEANUP

- A. Remove bituminous markings from finished surfaces.

- B. In areas where finished surfaces are soiled by work of this Section, consult manufacturer of surfaces for cleaning advice and conform to their instructions.
- C. Remove excess materials, trash, debris, equipment, and parts from the Work.
- D. Repair or replace defaced or disfigured finishes caused by work of this Section.

END SECTION

SECTION 07 51 30 – BUILT-UP ASPHALT ROOFING OVER LWIC

PART 1 – GENERAL

1.1 RELATED DOCUMENTS

- A. Drawings and general provisions of Contract, including General and Supplementary Conditions, general project requirements and Division 1 Specification Sections, apply to this Section.

1.2 SCOPE OF WORK

- A. Provide a complete roof system of mechanically attached base sheet; hot mopped felts, cap sheet, flashings, sealants and accessories over lightweight concrete (LWC) deck.
- B. Provide a complete weather and watertight temporary roof consisting of a gypsum board, a glaze coated two-ply asphalt and felt membrane, flashing and sealants.

1.3 BIDDER'S REPRESENTATION

- A. A large part of the value of this work is contained in the bidder's and the bidder's proposed manufacturer's capacity to provide long-term responsibility for the satisfactory performance of the roof. A 20-year, no dollar limit warranty is required. To that end, the following requirements are essential provisions of this specification:
 - 1. By offering a bid for this work, the bidder certifies that he has visited the site and determined that all the conditions of the surrounding and underlying work are consistent with his proposed manufacturer's requirements for the specified warranty. In the event that the bidder discovers any condition of the surrounding and underlying work that would prevent him or his manufacturer from providing the specified warranty, he shall report it to the design professional not less than ten days before the bid opening.
 - 2. By offering a bid for this work, the bidder certifies that he has examined the Contract Documents and has found all the details and requirements of the scope of work are complete and consistent with his proposed manufacturer's requirements for the specified warranty. In the event that the bidder discovers any detail or requirement in the Contract Documents that would prevent him or his manufacturer from providing the specified warranty, he shall report it to the design professional not less than ten days before the bid opening.
 - 3. By offering a bid for this work, the bidder certifies that he can, within ten calendar days of a notice of award from the Owner, provide a surety bond for the performance of the work, a surety bond for payment of labor and materials, and a specimen warranty certificate from the manufacturer whose system he proposes to use on the project.

1.4 QUALIFICATIONS

- A. Manufacturer Qualifications
 - 1. The manufacturer of the roofing system shall be the actual manufacturer of the roofing and insulation component materials, and shall have not less than fifteen (15) years of experience in the production of the specified system.
 - 2. The contractor shall include a certification from the manufacturer, on the manufacturer's letterhead, that the proposed membrane and insulation materials will be produced by the manufacturer of record.
- B. Installer Qualifications
 - 1. The installer of the built-up roofing shall have been engaged in the business of installing built-up roofing for not less than five (5) years and shall be experienced in the layout and application of this material. The crew shall be composed of experienced and skilled workers in this work.

1.5 SUBMITTALS

- A. Shop Drawings: Submit in accordance with Conditions of Contract and Division 1 Specification Sections, indicating roof size, membrane attachment layout, location, and type of penetrations, perimeter and penetration details, roof insulation make-up and layout.
- B. Product Data Submittals: Include manufacturer's technical product data, including UL product listing for each type of insulation, deck, fasteners and roofing product required.
- C. Fire Resistance: Provide roofing system, insulation, and component materials that have been tested for application and slopes indicated and are listed by Underwriters Laboratories, Inc. (UL) for Class A external fire exposure over decks specified herein.
- D. Wind Uplift: Provide rigid insulation, mechanically fastened roofing system, and component materials suitable for the structural deck and that have been tested as a complete system for application and slopes indicated. Provide a complete outfit of submittals ready for review. Allow sufficient time for review of the submittal. Provide fastening for uplift resistance to meet the applicable Building Code but in no case less than 90 psf.

1.6 INSPECTIONS

- A. During the roofing system installation, the Contractor shall take 5 digital photos daily of the work progress. The photos shall be forwarded to the Design Professional and the Owner daily with a brief caption of the roofing area being installed and the products being used.

- B. After the roof installation is complete, the manufacturer shall inspect the work and inform (by written report) the design professional, contractor, and the installer of defective/incomplete work to be remedied. Those areas indicated shall be corrected to the full satisfaction of the design professional, Owner, and manufacturer. The manufacturer shall submit written acceptance of the project to the design professional to issuance of the weather-tightness warranty.
- C. Inspections shall be performed at each transition of roof detail encountered for each phase of roofing for the duration of the project. An experienced, full-time employee of the manufacturer, with experience in similar inspections over the past two years, must conduct each inspection.
- D. As part of the District's initiative to ensure field quality control, a **Simulated Rain Test** shall be conducted as follows:
 - 1. After completion of the four ply-membrane installation and prior to the installation of the cap sheet membrane, a water test shall be coordinated and conducted by the Contractor in the presence of the Design Professional and the Owner's representative. The Contractor shall give the Design Professional and the Owner's representative a minimum of 48 hours' notice prior to conduction the water test. The Design Professional shall be responsible for documenting the water test results.
 - 2. Prior to the water test, the Contractor shall ensure that the roof area(s) to be tested have been cleaned of debris and all roof drains are sufficiently plugged.
 - 3. At the direction of the Owner's representative, apply simulated rain over all roof areas for at least 15 minutes per areas, or as otherwise directed.
 - 4. In addition to the simulated rain, direct water at all walls, windows, units, penetrations, etc. that occur adjacent to, or within each roof area, using a continuous, unforced hose steam.
 - 5. Plug all roof drains in each drainage area and allow each drain/scupper sump to be filled to a depth of 3-4 inches. Allow water to stand for a minimum of 2 hours. The Contractor shall maintain photo documentation of the sump locations that the water level has maintained a constant level for the time period required. These photos shall be provided to the Owner's representative upon request.
 - 6. Upon completion of the water test but before the end of each day, unplug drains and ensure the water flows freely without restriction. There will be no overnight testing.
 - 7. Perform any necessary corrections to defect noted (including the ensuring of positive drainage around all curbs, roof openings, and crickets to roof drains/scuppers) during or after the water test. Additional testing shall be performed as necessary to further define sources of any noted leakage. All defects and/or corrections shall be made prior to the installation of the cap sheet membrane and the Owner's representative shall be informed when the corrections are complete.

8. The Contractor shall provide and/or arrange for all necessary equipment, supplies, water, etc. as needed to perform these tests. This may include a water truck with a fire hose, if necessary.

1.7 WARRANTY

- A. **Manufacturer's Warranty:** Provide roofing manufacturer's total system leak-tight 20-year "No Dollar Limit Warranty," including insulation. Provide all details necessary to qualify for manufacturer's 20-year "No Dollar Limit Warranty".
- B. **Roofer's Guarantee:** Provide written guarantee from the Contractor stating that the Contractor will respond within 24 hours and repair within 5 business days, any leaks or defects in the roofing assembly for two (2) years at no cost to the Owner.

1.8 ENVIRONMENTAL REQUIREMENTS

- A. Install roofing materials only when surfaces are clean, dry, smooth and free of snow or ice.
- B. Do not apply roofing membrane during inclement weather or when ambient conditions will not allow proper application. Consult manufacturer's technical specifications on cold weather application.
- C. If during the course of this project, the rooftop mechanical equipment (heating and/or cooling) must be taken out of service to accomplish the work, the General Contractor shall provide temporary portable heating and/or cooling systems to maintain the building's interior environment equal to the building's own heating and/or cooling system.

PART 2 – PRODUCTS

2.1 MANUFACTURER

- A. Provide a mechanically attached base sheet, four-ply felt with a one ply mineral surfaced fiberglass cap sheet built-up roofing system. This is a minimum performance specification. Other manufacturer's systems may qualify, as determined by the design professional.

2.2 ROOF INSULATION PRODUCTS

- A. **Gypsum Board (Substrate for Temporary Roof):** Non-structural, moisture resistant gypsum panel. Gypsum board shall conform to ASTM C 1177 or ASTM C 1278. Gypsum board shall be supplied 4' x 8' sheets. Gypsum board shall be flat stock 5/8" thick. Gypsum board shall be pre-primed or field primed as applicable.
- B. Perlite cant strip complying with ASTM C-728.

- C. Mechanical Fasteners: Provide fasteners and plates listed in the approved report as part of the total assembly proposed. Fasteners shall be installed in patterns as required for the specified rigid insulation by the manufacturer to produce the required wind uplift resistance.

2.3 TEMPORARY ROOF

- A. Approved Roof:
 - 1. Johns Manville Roofing Systems Group
 - 2. GAF Material Corporation
- B. Roofing Felts:
 - 1. Ply Sheets: Two plies of asphalt-impregnated glass fiber mat complying with ASTM D2178, Type IV
- C. Roofing Bitumen:
 - 1. Low fuming/low odor asphalt bitumen complying with ASTM D 312. Asphalt shall be domestically manufactured in the United States and as approved by the roofing system manufacturer.
 - a. Approved Products:
 - i. Trulo by Owens Corning Trumbull
 - ii. No Smell Asphalt by Continental Materials
 - iii. No Smell Asphalt by United Asphalt
 - iv. Hot Stuff Asphalt's "Lite Packs"
 - b. Interply Moppings – Type III, IV
 - c. Glaze Coat – Type III
 - d. Flashings – Type III or IV, as recommended by the manufacturer
 - 2. Contractor shall provide and maintain a fume recovery system acceptable to the Owner for the duration of the project to control fumes/odors associated with bitumen kettles.
- D. Flashings
 - 1. Base Flashing Materials: Two plies of material base ply shall be SBS polymer modified bitumen reinforced with a polyester and/or glass fiber mat. (Top ply shall be the highly reflective fiberglass reinforced mineral cap sheet if a LEED project).

- E. Asphalt Roof Cement
 - 1. To comply with ASTM D 4586, asphalt roof cement (asbestos free) or roofing membrane manufacturer supplied SBS modified asphalt roof cement (asbestos free), as required.
- F. Related Materials
 - 1. Flashing securement devices shall be of adequate design to achieve substantial and positive anchorage.
 - a. Anchor bars for flashing securement to concrete or masonry substrates shall be 1/8" x 1" flat aluminum bar with 8" hole spacing by OMG, or approved equal.

2.4 ROOF SYSTEM

- A. Approved Manufacturer
 - 1. Johns Manville Roofing Systems Group, Specification 6GLC
 - 2. GAF Material Corporation, Specification N-B-6-M-/P6
- B. Roofing Felts
 - 1. Ply Sheets: Four plies of asphalt-impregnated glass fiber mat complying with ASTM D 2178, Type IV.
 - 2. Felt Envelopes: Non-perforated, asphalt-saturated organic roof felt complying with ASTM D 226, Type 1.
 - 3. Mineral surfaced fiberglass cap sheet complying with ASTM D 3909.
 - a. GlasKap by Johns Manville (GlasKap CR G for LEED projects).
 - b. GAF Glas Mineral Cap Sheet by GAF (EnergyCap for LEED projects).
 - 4. Venting base sheet complying with ASTM D 4897, Type II. One ply on all lightweight concrete decks.
 - a. Vensulation by Johns Maville Roofing Systems Group
 - b. Stratavent by GAF Materials Corporation
- C. Roofing Bitumens
 - 1. Low fuming/low odor asphalt bitumen complying with ASTM D 312. Asphalt shall be domestically manufactured in the United States and as approved by the roofing system manufacturer.
 - a. Approved Products:
 - i. Trulo by Owens Corning Trumbull
 - ii. No Smell Asphalt by Continental Materials

- iii. No Smell Asphalt by United Asphalt
 - iv. Hot Stuff Asphalt's "Lite Packs"
 - b. Interply Moppings – Type III, IV
 - c. Glaze Coat – Type III
 - d. Flashings – Type III or IV, as recommend by manufacturer
 - 2. Contractor shall provide and maintain a fume recovery system acceptable to the Owner for the duration of the project to control fumes/odors associates with bitumen kettles.
- D. Flashings
 - 1. Base Flashing Materials: Two plies of material base ply shall be SBS polymer modified bitumen reinforced with a polyester and/or glass fiber mat. (Top ply shall be the highly reflective fiberglass reinforced mineral cap sheet if a LEED project).
 - a. Dynalastic 180S and Glaskap (CR for LEED projects) by Johns Manville Roofing Systems Group.
 - b. Ruberoid Mop Smooth and GAF Glas Mineral Cap (EnergyCap for LEED projects) by GAF Material Corp.
 - 2. Strip Flashing Materials: One ply of granule-surfaced SBS polymer modified bitumen sheet reinforced with a polyester and/or glass fiber mat:
 - a. Dynalastic 180S by Johns Manville Roofing System Group
 - b. Ruberoid Mop Smooth by GAF Material Corporation
- E. Walkways
 - 1. Granule-surfaced modified asphalt boards:
 - a. DynaTred by Johns Manville Roofing Systems Group
 - b. 2-layers of SBS mopped together. Consult GAF Material Corporation
- F. Asphalt Roof Cement
 - 1. To comply with ASTM D 4586, asphalt roof cement (asbestos free) or roofing membrane manufacturer supplied SBS modified asphalt roof cement (asbestos free), as required.
- G. Related Materials
 - 1. Lead Flashing for roof drains shall be 27" x 27" and be minimum 4-pound lead.
 - 2. Pipe or vent jackets shall be minimum 3-pound lead with cap designed for use on flat roof construction.

3. Perma-Flash is an acceptable alternative to lead pipe jackets. Perma-Flash system requires 1 coat of TopGard Base Coat and 2 coats of TopGard 4000 to final product.
4. MajorSeal Liquid Flashing by GAF Material Corporation.
5. Wood Nailers: Shall be FTRW only on any roofing surfaces.
6. Flashing securement devices shall be of adequate design to achieve substantial and positive anchorage.
 - a. Anchor bars for flashing securement to concrete or masonry substrates shall be 1/8" x 1" flat aluminum bar with 8" hole spacing by OMG, or approved equal.

PART 3 – EXECUTION

3.1 INSPECTION

- A. The Contractor shall be responsible for suitable substrate to accept the roofing system.
- B. Installer of roofing system shall examine substrate and conditions under which roofing work is to be performed and shall notify the Architect and Owner representative immediately of unsatisfactory conditions. Do not proceed with roofing work until unsatisfactory conditions have been corrected in manner acceptable to installer and manufacturer.
- C. Before roofing work may begin, the design professional shall conduct a pre-roofing coordination meeting. It shall be attended by the Owner's representative, the PSFA representative, as necessary, the general contractor, the roofing contractor, the roofing manufacturer's representative and all other subcontractors who have any components of their work on or penetrating the roof. The participants shall:
 1. As much as is possible by visual inspection and by the cutting of core samples, verify that surfaces and site conditions are ready to receive work.
 2. Examine roof deck to determine that it is sufficiently rigid to support roofers and their mechanical equipment and that deflection will not strain or rupture roof components or deform deck.
 3. Verify deck is clean and smooth, free of depressions, waves, or projections, properly sloped to insure drainage. Examine substrate to determine that surface is in a suitable condition for roofing work.
 4. Verify roof openings, curbs, pipes, sleeves, ducts, and vents through roof are solidly set, and cant strips, wood nailing strips and reglets are in place. Verify that all curbs and penetrations have been laid out and installed with adequate vertical and horizontal clearance as required by the manufacturer to provide the specified warranty.

5. The condition of surface to receive roof insulation shall be firm, clean, smooth, and dry. Do not start roof application until defects have been corrected.

3.2 INSTALLATION

- A. General: Comply with manufacturer's written instruction for installation of the roof system.
- B. All flashings shall be installed concurrently with the roofing membrane as the job progresses. No temporary flashings shall be allowed without the prior written approval of the Owner's Representative. If any water is allowed to enter under the newly completed roofing due to incomplete flashings, seams and or night seals, the affected area shall be removed and replaced at the Applicator's expense.
- C. Phased Construction & Completion Requirements:
 1. Phased construction will not be permitted on this project. However, if, due to a foreseeable weather event, phased construction is required, the Contractor shall request (in writing) the approval of phased construction from the Design Professional, roofing manufacturer, and the Owner's Representative.

3.3 WOOD NAILER LOCATION AND INSTALLATION

- A. Nailers are to be installed as per detail drawings.
- B. Discard units of material with defects that might impair quality of work and units that are too small to use in fabricating work with minimum joints or optimum joint arrangement.
- C. Set nailers to required levels and lines with members plumb and true.
- D. All perimeter nailers shall be of uniform height within a given roof section.
- E. Nailers shall be installed with $\frac{1}{4}$ " gap between ends of adjoining pieces.
- F. Nailers shall be fastened in accordance with the following schedule:
 1. Fasteners in 6" or wider (nominal) lumber shall be installed in two (2) rows, staggered one-third of nailer width. Listed spacings indicate distance between fasteners in adjacent rows.
 2. Two (2) fasteners shall be installed within 6" of each nailer end.
 3. Corner fastener spacing shall extend 8' from all outside building corners.
 4. Where two or more nailers are installed, each nailer shall be fastened independently.
 5. Over all deck types, the bottom nailer shall be fastened using the specified fasteners and $\frac{5}{8}$ " washers. Countersink washers and fasteners level with top of wood using spade bit or similar method. Fasten subsequent nailers, where specified, using the specified screws without washers.

6. When nailers are stacked, stagger the layer ends no less than 24".
7. Unless noted otherwise on the drawings, nailers should be installed as detailed in the Nailer Attachment Schedule 06 10 00, 3.1 Nailers).

3.4 INSULATION INSTALLATION (SUBSTRATE FOR THE TEMPORARY ROOF)

- A. Install Insulation: Install only as much insulation as can be covered with the temporary roof and completed before the end of the day's work or before the onset of inclement weather.
- B. Fit Insulation: Neatly fit insulation to all penetrations, projections, and nailers. Insulation should be loosely fitted, with gaps greater than 1/4" being filled with acceptable insulation. Under no circumstances should the membrane be left unsupported over a space greater than 1/4". Tapered or feathered insulation should be installed around roof drains so as to provide proper slope for drainage.
- C. Attach Insulation: Insulation must be attached using Fasteners and Insulation Plates. Refer to the Technical Information for attachment patterns and rates for specific insulation types and thickness. In a multi-layer insulation assembly, the type and thickness of the top layer of insulation determine fastening pattern. Insulation fasteners shall penetrate the top of the flutes and shall not extend into the building interior. Roofing contractor is liable for replacing fasteners that extend beyond the bottom of the flutes.
- D. Stagger Insulation Joints: When installing multiple layers of insulation, all joints between layers should be staggered.

3.5 TEMPORARY ROOF INSTALLATION

- A. Asphalt Bitumen Heating: Heat and apply bitumen in accordance with equiviscous temperature method ("EVT Method") as recommended by NRCA. Do not raise temperature above minimum normal fluid-holding temperature necessary to attain EVT (plus 25°F at point of application) more than one hour prior to time of application. Discard bitumen that has been held at temperature, exceeding finished blowing temperature (FBT) for a period exceeding 3 hours.
- B. Contractor shall provide and maintain a fume recovery system acceptable to the Owner for the duration of the project to control fumes/odors associated with bitumen kettles.
- C. Quality Control: Contractor's asphalt kettle shall be equipped with an accurate built-in thermometer. Contractor shall also have available at the site and additional portable thermometer for checking temperature of asphalt at the point of application and for use as a check on the kettle thermometer.

- D. Bitumen Mopping Weights: For interplay mopping, and for other moppings except as otherwise indicated, apply bitumen at the rate of 25 pounds of asphalt (plus or minus 25 percent on a total-job average basis) per roof square (100 sq. ft.) between plies.
- E. Substrate Joint Penetrations: Do not allow bitumen to penetrate substrate joints and enter building or other construction. Where mopping is applied directly to a substrate, tape joints or, in the case of steep asphalt, hold mopping back 2 inches from both sides of each joint.
- F. Cutoffs: At end of each day's roofing installation, protect exposed edge of incomplete work, including ply sheets and insulation. Provide temporary covering of 2 plies of No. 15 roofing felt set in full moppings of hot bitumen; remove at beginning of next day's work. Glaze-coat areas of completed organic ply sheets before end of each day's work.
- G. If applicable prime the substrate board or concrete deck with ASTM D 41 asphalt primer at the rate of 3/4 gallon per 100 per square feet. The primer shall be allowed to dry prior to temporary roof application.
- H. The temporary roofs shall consist of two-ply ASTM D 2178 Type IV glass felts installed in uniform solid mopping of ASTM D 312 Type 111 low fuming/low odor asphalt over a primed concrete deck or a primed substrate board.
- I. Four-inch (4") cants shall be fully adhered at all wall/curb transitions.
- J. Flashing shall consist of two-ply ASTM D 2178 Type IV glass felts installed in uniform solid mopping of ASTM 312 Type III low fuming/low odor asphalt. Flashing shall extend a minimum of 6" above the roof deck. The top edge of all flashing shall be fastened at 6" o.c. with 1" cap nails or other appropriate/approved fastener. The top edge of all flashing shall be three- coursed with roof cement and reinforcement fabric.
- K. All temporary roofing and flashing shall be glazed coated with asphalt at the end of each working day.

3.6 MEMBRANE AND FLASHING INSTALLATION

- A. Asphalt Bitumen Heating: Heat and apply bitumen in accordance with equiviscous temperature method ("EVT Method") as recommended by NRCA. Do not raise temperature above minimum normal fluid-holding temperature necessary to attain EVT (plus 25°F at point of application) more than one hour prior to time of application. Discard bitumen that has been held at temperature, exceeding finished blowing temperature (FBT) for a period exceeding 3 hours.
- B. Quality Control: Contractor's low fume recovery equipped asphalt kettle shall be equipped with an accurate built-in thermometer. Contractor shall also have available at the site and additional portable thermometer for checking temperature of asphalt at the point of application and for use as a check on the kettle thermometer.

- C. Bitumen Mopping Weights: For inter-ply mopping, and for other moppings except as otherwise indicated, apply bitumen at the rate of 25 pounds of asphalt (plus or minus 25 percent on a total-job average basis) per roof square (100 sq. ft.) between plies.
- D. Substrate Joint Penetrations: Do not allow bitumen to penetrate substrate joints and enter building or damage insulation, vapor retarders, or other construction. Where mopping is applied directly to a substrate, tape joints or, in the case of steep asphalt, hold mopping back 2 inches from both sides of each joint.
- E. Cutoffs: At end of each day's roofing installation, protect exposed edge of incomplete work, including ply sheets and insulation. Provide temporary covering of 2 plies of No. 15 roofing felt set in full moppings of hot bitumen; remove at beginning of next day's work. Glaze-coat areas of completed organic ply sheets before end of each day's work.
- F. Base Sheet: Ventilating base sheet at all designated locations. Mechanically fasten as required to provide required wind uplift resistance.
- G. Roof Membrane Installation: Apply a piece $g \bullet$ wide, then over that, one 18" wide, then over that, one 27" wide. Over these 3 partial sheets install a full width 36" piece. The following felts are to be applied full width, overlapping the preceding felts by 27-1/2" so that at least 4 plies of felt cover the substrate at all locations. Install each felt so that it is firmly and uniformly set, without voids, into the hot bitumen (within $\pm 25^{\circ}\text{F}$ of the EVT) applied just before the felt at a nominal rate of 23 lbs. per square, over the entire surface. Installation over porous substrates such as roof insulation may require up to 33 lbs. of hot bitumen per square.
- H. Surfacing: Prior to application of the fiberglass reinforced mineral surfaced cap sheet, cut the cap sheet into handle able lengths (12' -18'). Lay the material out on the roof and allow it to relax and flatten. To accommodate a full width sheet, apply a mopping of hot asphalt, approximately 20°F above the EVT, at a nominal rate of 25 lbs. per square. (The higher temperature of asphalt maximizes the bonding of the cap sheet to the ply felts). Then flop the cap sheet into the hot asphalt. On subsequent courses, the cap sheet is positioned upside down, directly over the sheet in the preceding course such that the side lap area of the preceding sheet is exposed. Care should be taken to maintain 2" side laps and 6" end laps. Asphalt is applied in the same manner as before, making sure to also cover the 2" exposed side lap. Asphalt may also be applied to the exposed "upside down" cap sheet, prior to "flopping" it into the hot asphalt. The cap sheet must be firmly and uniformly set, without voids, into the hot asphalt with all edges and laps well sealed.
- I. Care shall be taken not to track bitumen onto the finished exposed membrane. Full adhesion shall be achieved and all edges shall be well sealed. Leading and trailing edges of T-laps in both plies shall be hand rolled to prevent formation of voids. Asphalt shall bleed out "to Y2" at laps. #11 color matched granules shall be broadcast into asphalt bleed out while hot so that the finished appearance is uniform and neat.
- J. Set-On Accessories: Where small roof accessories are set on built-up roofing membrane, set metal flanges in a bed of roofing cement and seal penetration of membrane with bead of roofing cement to prevent flow of bitumen from membrane.

- K. Composition Flashing and Stripping: Install composition flashing at cant strips and other sloping and vertical surfaces, at roof edges, and at penetrations through roof.
- L. Application of Base Flashing: The roofing membrane must extend to the top of the cant. The completed base flashing shall extend not less than 9" or more than 24" above the level of the roof, and shall extend onto the roof membrane a minimum of 4".
1. Starting just below the point on the parapet where the base flashing will terminate, mop the parapet and the surface of the roofing felts on the cant with hot Type III or Type IV asphalt. Immediately place the backer felt into the hot bitumen, smoothing the felt to set it firmly into the bitumen. The bottom edge of the backer felt should terminate at the bottom edge (base) of the cant. Do not extend the backer felt onto the horizontal membrane surface. Laps in the backer felt should be a minimum of 2".
 2. All flashings shall be installed in 39" long pieces, cut from the end of the roll. Starting just above the top edge of the backer felt, mop the wall, the surface of the backer felt, and out onto the roof membrane with hot Type III or IV asphalt. Holding the upper corners of the flashing, position its lower horizontal edge on the roof membrane (minimum 4" from base of the cant) and lay it into place over the cant strip and up the wall. The sheet should be "worked-in" to ensure that it is firmly and uniformly bonded. In cool or cold weather, the back of the flashing sheet should also be mopped with the hot bitumen, and shorter lengths of flashing should be used. Laps in the flashing should be minimum of 3" and be well sealed.
 3. Mechanically fasten the base flashing on 6" centers along its top edge. Fasteners must have a 1" minimum diameter integral cap, or be driven through 1" minimum diameter rigid metal discs.
 4. All inside and outside corners and vertical laps shall be three-coursed with asphalt roof-cement and reinforcing fabric, with #11 color matched granules broadcast and pressed into the cement while wet.
- M. Roof Drains: Fill clamping ring base with a heavy coating of roofing cement. Extend built-up roofing membrane into clamping ring or, where not feasible, provide two plies of glass-fiber-reinforced flashing mopped with Type III asphalt and extended into clamping ring. Extend flashings onto built-up asphalt roofing system 6 inches and 10 inches, respectively.
- Before placing clamping ring, set 2 plies of glass-fiber fabric in roofing cement and coat with roofing cement. Extend each fabric into clamping ring and for distances of 14 inches and 16 inches, respectively, onto built-up roofing.
- N. Installation of Roof Accessories: Miscellaneous sheet metal accessory items, including insulation vents and other devices, and major items of roof accessories (if any) to be coordinated with built-up roofing system work, are specified in other sections of these specifications.

3.7 PROTECTION

- A. Protect building surfaces against damage from roofing work. Where traffic must continue over finished roof membrane, protect surfaces.

3.8 TEMPORARY CLOSURE

- A. Temporary closures to ensure that moisture does not damage any completed section of the new roofing system are the responsibility of the roofing contractor. Completion of flashing, terminations, and temporary closures should be completed as required to provide a watertight condition. Any material contaminated by a temporary closure must be cut out and discarded prior to resumption of installation.

3.9 CLEANUP

- A. Remove bituminous markings from finished surfaces.
- B. In areas where finished surfaces are soiled by work of this Section, consult manufacturer of surfaces for cleaning advice and conform to their instructions.
- C. Remove excess materials, trash, debris, equipment, and parts from the Work.
- D. Repair or replace defaced or disfigured finishes caused by work of this Section.

END SECTION

Exhibit A – FRTW Nailer Attachment Guidelines (Info Only)

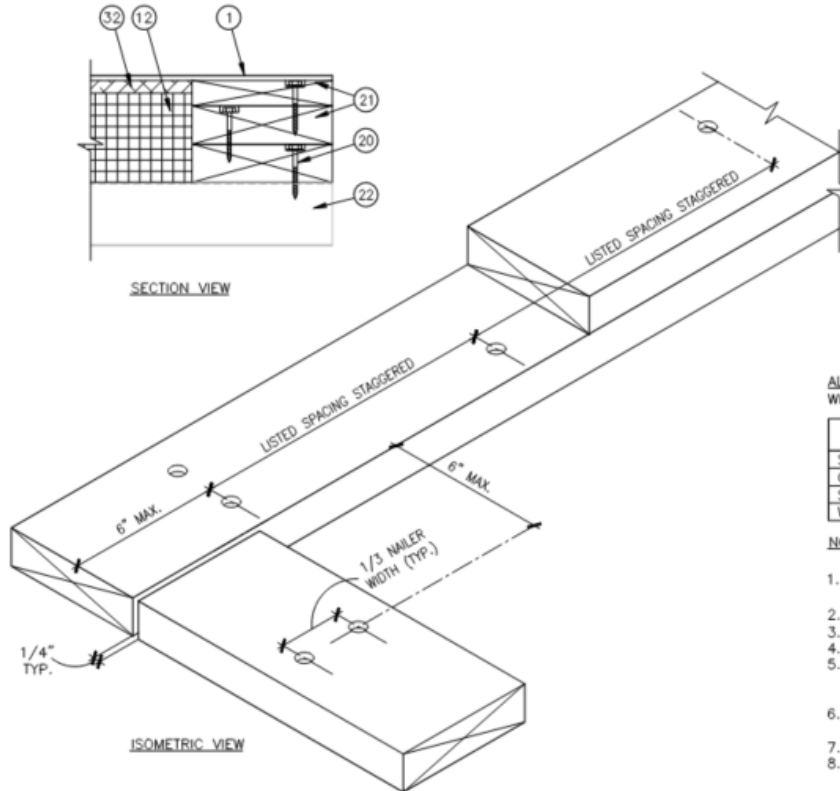

ALL PERIMETER NAILERS, NEW OR EXISTING SHALL BE FASTENED IN ACCORDANCE WITH THE FOLLOWING SCHEDULE (UNLESS NOTED OTHERWISE ON DETAIL DRAWINGS)

ATTACHMENT SUBSTRATE	PERIMETER FASTENER SPACING (MAXIMUM)	CORNER FASTENER SPACING (MAXIMUM)
STRUCTURAL CONCRETE	12" O.C.	6" O.C.
CMU (FASTENER INTO SOLID MATERIAL)	12" O.C.	6" O.C.
STEEL DECK	12" O.C.	6" O.C.
WOOD	12" O.C.	6" O.C.

NOTES:

1. FASTENERS IN 6" OR WIDER (NOMINAL) LUMBER SHALL BE INSTALLED IN TWO (2) ROWS, STAGGERED 1/3 OF NAILER WIDTH.
2. TWO (2) FASTENERS SHALL BE INSTALLED WITHIN 6" OF EACH NAILER END.
3. CORNER FASTENER SPACING SHALL EXTEND 8' FROM ALL OUTSIDE BUILDING CORNERS.
4. WHERE TWO OR MORE NAILERS ARE INSTALLED, EACH NAILER SHALL BE FASTENED INDEPENDENTLY.
5. OVER ALL DECK TYPES, THE BOTTOM NAILER SHALL BE FASTENED USING THE SPECIFIED FASTENERS AND 5/8" DIAMETER WASHERS. COUNTERSINK WASHERS AND FASTENERS LEVEL WITH THE TOP OF WOOD USING SPADE BIT OR SIMILAR METHOD.
6. FASTENER TYPES ARE DETERMINED BY SUBSTRATE MATERIALS AND SECTION 061000 ROUGH CARPENTRY.
7. NAILERS SHALL BE INSTALLED WITH 1/4" GAP BETWEEN ENDS OF ADJOINING PIECES.
8. REFER TO SECTION 061000 FOR ADDITIONAL REQUIREMENTS.

A4 TYP. F.R.T.W. WOOD NAILER ATTACHMENT GUIDELINES
3" = 1'-0"

2009.02 A051 10

KEYED NOTES

1. NEW BUILT-UP ROOFING SYSTEM MEMBRANE.
12. RIGID INSULATION. THICKNESS VARIES.
20. BOTTOM NAILER. FASTEN WITH WASHERS, COUNTERSINK FASTENERS.
21. ADDITIONAL NAILERS. FASTEN WITHOUT WASHERS, COUNTERSINK FASTENERS.
22. EXISTING METAL DECK.
32. 1/2" RECOVERY BOARD.